

MUSTANG VALLEY WATER SUPPLY



CORPORATION

TARIFF

REVISION 06-17-2024

This tariff replaces all previous versions.

Mustang Valley Water Supply Corporation
301 N 3rd St, Suite A / PO Box 6, Cranfills Gap, TX, 76637
Phone: 254 / 597-2445

Table of Contents

SECTION A. RESOLUTIONS	4
SECTION B. STATEMENTS	5
SECTION C. DEFINITIONS	7
SECTION D. GEOGRAPHIC AREA SERVED	10
SECTION E. SERVICE RULES AND REGULATIONS	12
1. Service Entitlement.....	12
2. Service Location and Classification.....	12
3. Service Requirements.....	12
4. Ownership of equipment.....	13
5. Activation of Standard Service.....	13
6. Activation of Non-Standard Service.....	13
7. Changes in Service Classification.....	13
8. Membership.....	13
9. Owners and Renters.....	15
10. Denial of Service.....	16
11. Applicant’s or Transferee’s Recourse.....	16
12. Insufficient Grounds for Refusal of Service.....	16
13. Deferred Payment Agreement.....	16
14. Charge Distribution and Payment Application.....	16
15. Due Dates, Delinquent Bills, and Service Disconnection Date.....	17
16. Rules for Disconnection of Service.....	17
17. Billing Cycle Changes.....	20
18. Back-billing.....	20
19. Disputed Bills.....	20
20. Inoperative Meters.....	20
21. Bill Adjustment.....	20
22. Meter Tampering and Damage to Property.....	20
23. Meter Relocation.....	21
24. Prohibition of Multiple Connections To A Single Tap.....	21
25. Master Metered Account Regulations.....	21
26. Member’s Responsibility.....	22
SECTION F. DEVELOPER, SUBDIVISION AND NON-STANDARD SERVICE REQUIREMENTS	23
Part I. General Requirements.....	23
1. Purpose.....	23
2. Application of Rules.....	23
3. Non-Standard Service Application.....	23
4. Design.....	24
5. Non-Standard Service Contract.....	24
6. Construction of Facilities by Applicant Prior to Execution of Service Contract.....	25
7. Dedication of Water System Extension to WSC.....	25
8. Property and Right-of-Way Acquisition.....	25
9. Bids For Construction.....	25
10. Pre-Payment For Construction and Service.....	26
11. Construction.....	26

PART II. Request for Service to Subdivided Property	26
1. Sufficient Information	26
2. Service within Subdivisions	26
3. Final approval	28

SECTION G. RATES AND SERVICE FEES 29

1. Service Investigation Fee (Hydraulic Study)	29
2. Membership Fee	29
3. Easement Fee	29
4. Installation Fee	29
5. System Buy-In Fee	30
6. Monthly Charges	30
7. Assessments	30
8. Late Payment Fee	31
9. Owner Notification Fee	31
10. Mortgagee/Guarantor Notification Fee	31
11. Returned Check Fee	31
12. Reconnect Fee	31
13. Service Trip Fee	31
14. Equipment Damage Fee	31
15. Meter Tampering and Damage to Property Penalty	31
16. Customer History Report Fee	31
17. Meter Test Fee	31
18. Transfer Fee	31
19. Non-Disclosure Fee	32
20. Information Copy Fee	32
21. Customer Service Inspection Fee	32
22. Franchise Fee Assessment	32
23. Regulatory Assessment	32
24. Additional Assessments	32
25. Other	32

SECTION H. DROUGHT CONTINGENCY AND EMERGENCY WATER DEMAND MANAGEMENT PLAN 33

1. Introduction	33
2. Coordination with Regional Water Planning Group	33
3. Trigger Conditions	33
4. Stage Levels of Water Allocations	34
5. Initiation and Termination Procedures	34
6. Penalties for Violations	35
7. Exemptions or Waivers	35
8. Variance	36
9. Implementation	36

SERVICE APPLICATION AND AGREEMENT	37
-----------------------------------	----

Approved DLK
Revision Date: January 1, 2023

MUSTANG VALLEY WATER SUPPLY CORP.
IS AN EQUAL OPPORTUNITY PROVIDER.

SECTION A
RESOLUTIONS

THE BOARD OF DIRECTORS OF MUSTANG VALLEY WATER SUPPLY CORPORATION ESTABLISHES THAT:

1. This Tariff of the Mustang Valley Water Supply Corporation ("Corporation"), serving in parts of Bosque County and Coryell County consisting of Sections A through H is adopted and enacted as the current regulations and policies effective as of March 21, 2017.
2. Only those preexisting written contracts or agreements executed by the present or previous Board of Directors shall remain in effect, unless the contract or agreement requires compliance with changes of the tariff from time to time.
3. The adoption or revisions of this tariff does not prohibit or limit the Corporation from enforcing previous penalties or assessments from before the current effective date.
4. An official copy of this and all policies or records shall be available during regular office hours of the Corporation. The Administrative Manager of the Corporation shall maintain the original copy as approved and all previous copies for exhibit.
5. Rules and regulations of state or federal agencies having jurisdiction shall supersede any terms of this policy. If any section, paragraph, sentence, clause, phrase, word or words of this policy are declared unconstitutional or invalid for any purpose, the remainder of this policy shall not be affected.
6. This tariff has been revised in compliance with the Open Meeting Act, Chapter 551, of the Texas Government Code.

PASSED and APPROVED this 16th day of November, 2019.

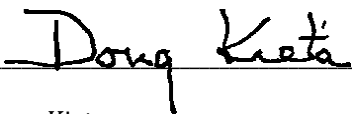

Doug Kieta,
President, Mustang Valley Water Supply Corporation

SEAL

ATTEST:

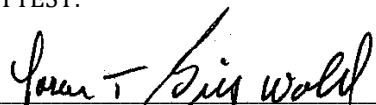

Secretary, Mustang Valley Water Supply Corporation

Approved DLK
Revision Date: January 1, 2023

MUSTANG VALLEY WATER SUPPLY CORP.
IS AN EQUAL OPPORTUNITY PROVIDER.

SECTION B
STATEMENTS

1. **Organization.** The Mustang Valley Water Supply Corporation (“Corporation”) is a Member-owned, non-profit corporation incorporated pursuant to the Texas Water Code Chapter 67, and the provisions of the Texas Business Organizations Code applicable to Member-owned, Member-controlled non-profit corporations for the purpose of furnishing potable water utility service. Corporation operating policies, rates and regulations are adopted by the Board of Directors elected by the Members of the Corporation.
2. **Non-Discrimination Policy.** Membership in the Corporation and service is provided to all Applicants who comply with the provisions of this Tariff regardless of race, creed, color, national origin, sex, disability or marital status.
3. **Policy and Rule Application.** These policies, rules, and regulations apply to the water services provided by the Corporation. Failure on the part of the Member or Applicant to observe these policies, rules and regulations gives the Corporation the authority to deny or discontinue service according to the terms of this Tariff as amended from time to time by the Board of Directors of the Corporation.
4. **Corporation Bylaws.** The Corporation Members have adopted bylaws which establish the make-up of the Board of Directors and other important regulations of the Corporation. The bylaws are on file at the Corporation’s office and website.
5. **Fire Protection Responsibility.** The Corporation does not provide nor imply that fire protection is available throughout the distribution system, except where expressly required by municipal ordinance or agreed to by the Corporation. All flush valves are for the operation and maintenance of the system and may be used by authorized fire departments.
6. **Damage Liability.** The Corporation is not liable for damages caused by service interruptions, leaks, PRV failures, regulator failures and other events beyond its control or normal system failures. By acceptance of Membership, the Member consents to waiver of such liability.
7. **Information Disclosure.** The records of the Corporation shall be kept in the Corporation office in Cranfills Gap, Texas. All information collected, assembled, or maintained by or for the Corporation shall be disclosed to the public in accordance with the Texas Public Information Act. **In no event and under no circumstances shall the Corporation disclose the Social Security Number of any Member to any person other than an employee of the Corporation.** An individual customer may request in writing that their address, telephone number, and account records be kept confidential. Such confidentiality does not prohibit the utility from disclosing this information to an official or employee of the state or a political subdivision of the state acting in an official capacity or an employee of the Corporation acting in connection with the employee’s duties. Further, such confidentiality does not prohibit the Corporation from disclosing the name and address of each Member entitled to vote on a list to be made available to the Corporation’s voting Members, or their agents or attorneys, in connection with a meeting of the Corporation’s Members. The Corporation shall give its applicants and customers notice of rights to confidentiality under this policy and all prevailing associated fees for such request.
8. **Member Notice Provisions.** The Corporation shall give written notice of monthly rate changes by USPS mail, email, website or hand delivery to all Members at least 30 days prior to the effective date of the new rate. The notice shall contain the old rates, new rates, effective date of the new rate, date of Board authorization, and the name and phone number of the Corporation’s contact person designated to address inquiries about the rate change.
9. **Grievance Procedures.** Any Member of the Corporation or individual demonstrating an interest under the policies of this Tariff in becoming a Member of the Corporation shall have an opportunity to voice concerns or grievances to the Corporation by the following means and procedures:
 - a. By presentation of concerns to the Corporation’s manager or authorized staff member. If not resolved to the satisfaction of the aggrieved party then,
 - b. By presenting a letter to the Board of Directors stating the individual’s grievance or concern and the desired result.
 - c. The Board of Directors shall respond to the complaint by communicating the Board’s decision in writing.

Approved DLK
Revision Date: January 1, 2023

MUSTANG VALLEY WATER SUPPLY CORP.
IS AN EQUAL OPPORTUNITY PROVIDER.

- d. Any charges or fees contested as a part of the complaint in review by the Corporation under this policy shall be suspended until a satisfactory review and final decision has been made by the Board of Directors.

10. Customer Service Inspections. The Corporation requires that a service inspection certification be completed by a licensed Customer Service Inspector prior to providing continuous water service to new construction and for all new Members as part of the activation of standard and some non-standard service. Member service inspections are also required on any existing service when the Corporation has reason to believe that cross-connections or other potential contaminant hazards exist, or after any material improvement, correction or addition to the Members' water distribution facilities. This inspection is limited to the identification and prevention of cross connections, potential contaminant hazards and illegal lead materials. (30 TAC 290.46(j)) (See Tariff Section G.1.)

11. Submetering Responsibility. Submetering and Non-Submetering by Master Metered Accounts may be allowed in the Corporation's water distribution system provided the Master Metered Account customer complies with the Texas Commission on Environmental Quality Chapter 291, Subchapter H rules pertaining to Submetering. The Corporation has no jurisdiction or responsibility to the tenants; tenants receiving water under a Master Metered Account are not considered customers of the Corporation. Any interruption or impairment of water service to the tenants is the responsibility of the Master Metered Account Customer. Any complaints regarding submetering should be directed to the Texas Commission on Environmental Quality.

NOTE: The Corporation should check with the Master Metered Account Customer to:

- See if they have registered with the TCEQ, (Texas Water Code Chapter 13 Subchapter M.)
- See that they do not charge their tenants more than the total amount of charges billed. If the aggregate bill is greater than the Corporation's charge, the Master Metered Account Customer is considered by the TCEQ to be a separate Public Water System and will be required to comply with all TCEQ regulations.
- Protect the System's CCN. Should the Master Metered Account Customer continue to violate these or other State regulations, the Corporation shall request a Cease-and-Desist Order from the TCEQ. (Texas Water Code Section 13.252 and 30 TAC Section 291.118)

12. Prohibition Against Reselling of Water Under Standard Contract. The meter connection is for the sole use of the Member and is to provide service to only one (1) dwelling or one (1) business. Extension of pipe(s) to share or resell water to any other persons, dwellings, businesses, or property, etc., is prohibited.

SECTION C
DEFINITIONS

- Active Service** – The status of any Member receiving authorized service under the provisions of this Tariff.
- Applicant** – A person, partnership, cooperative corporation, corporation, agency, public or private organization of any type applying for service with the Corporation. A person must have reached age of maturity (18) in Texas to apply for service. (Section 129.001, Civil Practice & Remedies Code)
- Automatic Meter Reading (AMR) Device** – a technology used in utility meters for collecting the data that is needed for billing purposes. AMR, which works by translating the movement of the mechanical dials on a meter into a digital signal, does not require physical access or visual inspection.
- Base Rate** – The monthly charge assessed each Member for the opportunity of receiving service. The Base Rate is a fixed rate based upon the meter size as set forth in Tariff Section G.
- Board of Directors** – The governing body elected by the Members of the Corporation that is vested with the management of the affairs of the Corporation. (Section 22.001(1), Texas Business Organizations Code)
- Bylaws** – The rules pertaining to the governing of the Corporation adopted by the Corporation Members. (Section 22.001(2), Texas Business Organizations Code)
- Certificate of Convenience and Necessity (CCN)** – The authorization granted under Chapter 13 Subchapter G of the Texas Water Code for the Corporation to provide water utility service within a defined territory. The Corporation has been issued Certificate Number 11175. Territory defined in the CCN shall be the Certificated Service Area. (See Tariff Section D. Certificated Service Area Map)
- Corporation** – The Mustang Valley Water Supply Corporation. (Tariff Section A.1.)
- Customer Service Inspection** – A customer service inspection is an examination of the private water distribution facility for the purpose of providing or denying water service. The inspection is limited to the identification and prevention of cross-connections, potential contaminant hazards, and illegal lead materials. Customer service inspections are completed before providing continuous water service to new construction on any existing service where there is a reason to believe that cross-connections or other potential contaminant hazards exist, or after any material improvement, correction, or addition to private water distribution facilities. (TCEQ)
- Developer** – Any person, partnership, cooperative corporation, corporation, agency, or public or private organization who subdivides land or requests two (2) or more water service connections on a single contiguous tract of land [as defined in Section 13.2502 (e)(1) of the Texas Water Code].
- Disconnection of Service** – The discontinuance of water service by the Corporation to a Member.
- Easement** – A private perpetual dedicated right-of-way for the installation of water pipelines and necessary facilities which allows access to property for future operation, maintenance, facility replacement, facility upgrades, and/or installation of additional pipelines (if applicable) for both service to an Applicant and system-wide service. This may also include restrictions on the adjacent area to limit the installation of sewer lines or other facilities that would restrict the use of any area of the easement. (Sample Application Packet, Form-RUS-TX 442-8 (Rev. 6-06) or Form RUS-TX 442-9 (Rev. 6-06)) The easement will be filed in the real property records of the appropriate county or counties.
- Final Plat** – A complete plan for the subdivision of a tract of land showing or referencing Local Tax Appraisal Maps, access to public road(s), number and size of lots, location of dedicated easements, and location(s) of lakes, streams, or rivers through the property. The Corporation shall determine if a plat submitted for the purpose of this Tariff shall qualify as a final plat. For purposes of evaluating Subdivision service requests under Section F, the Corporation may accept preliminary plats or plats awaiting final approval pending execution of agreement for service by the Corporation.
- Hazardous Condition** – A condition that jeopardizes the health and welfare of the Members/Consumers of the Corporation as determined by the Corporation or regulatory authority.
- Liquidated Membership** – A Membership that has been canceled due to delinquent charges exceeding the Membership Fee or for other reasons as specified in this Tariff.

Approved DLK
Revision Date: January 1, 2023

MUSTANG VALLEY WATER SUPPLY CORP.
IS AN EQUAL OPPORTUNITY PROVIDER.

- Member** – Any person, partnership, cooperative corporation, corporation, agency, or public or private organization who holds a Membership in the Corporation and who is a record owner of the property served, that has qualified for service and been certified as a Member in accordance with the Corporation’s Tariff. (Texas Water Code Section 13.002(11), Texas Water Code Section 67.016(d))
- Membership** – A non-interest-bearing stock or right of participation purchased from the Corporation evidencing a Member’s interest in the Corporation. (See Tariff Section E.8.b and Texas Business Organizations Code Sections 22.053, 22.151(c))
- Membership Fee** – A fee qualified as such under the terms of the tariff and the bylaws of the Corporation assigned to the real estate designated to receive service. The Membership fee shall be refundable upon termination of service and surrendering the Membership. The Membership fee cannot be more than 12 times the minimum monthly base rate. (30 TAC Section 291.3(25) Definitions, Texas Water Code Section 13.043(g)) **Proof of Ownership** – For the purpose of this tariff, applicants for service and Membership shall provide proof of ownership of the real estate to be served by deed of trust, warranty deed, or other recorded documentation. (Texas Water Code Section 67.016(d))
- Public Utilities Commission of Texas (PUC)** – State regulatory agency having jurisdiction of water service utilities and appellate jurisdiction over the rates and fees charged by Non-Profit Water and Sewer Service Corporations.
- Rural Utilities Service (RUS)** – An agency of the United States Department of Agriculture Rural Development Mission Area that provides loan and grant funds for development of rural water and sewer systems serving communities with a population of less than ten thousand (10,000) people.
- Renter** – A consumer who rents or leases property from a Member or who may otherwise be termed a tenant. (See Tariff Section E.9.)
- Re-Service** – Providing service to an Applicant at a location for which service previously existed and where there is an existing setting for a meter. Costs of such re-servicing shall be based on justifiable expenses in connection with such re-servicing. (See Tariff Section E.5b)
- Service Application and Agreement** – A written agreement between the Member/Applicant and the Corporation defining the specific type of service requirements requested on the current service application and agreement form, and the responsibilities of each party required before service is furnished. (See Sample Application Packet RUS-TX Bulletin 1780-9 (Rev. 01/09) or Non-Standard Service Contract)
- Service Investigation Fee** – A fee paid by a potential Member of the Corporation for the purpose of determining the feasibility of a construction and /or expansion project. The Indication of Interest Fee is for purposes of performing a hydraulic investigation to determine if the requested connection is feasible. This fee is non-refundable. This fee also applies to applicants applying for, or receiving Temporary Service. (Tariff Section G.1., and Sample Application Packet - USDA RUS-TX Bulletin 1780-9 (Rev. 01/09))
- Service Unit** – The base unit of service used in facilities design and rate making. For the purpose of this tariff, a service unit is a 5/8” X 3/4” water meter. (See Tariff Section G.6.)
- Subdivide** – To divide the surface area of land into lots or tracts. (Texas Local Government Code Section 232.021(11) Definitions, Texas Water Code Section 13.2502(e)(1))
- Subdivider** – An individual, firm, corporation, or other legal entity that owns any interest in land and that directly or indirectly subdivides land into lots as a part of a common promotional plan in the ordinary course of business. (Texas Local Government Code Section 232.021(12) Definitions)
- Subdivision** – An area of land that has been subdivided into lots or tracts. (Local Government Code Section 232.021(13) Definitions)
- System Buy-In Fee** – Each Applicant for new service where a new service tap is necessary shall be required to achieve parity with the contributions to the construction of the Corporations facilities capacity that have been made previously by existing Members. This fee shall be assessed prior to providing or reserving service on a per service unit basis for each property and shall be assigned and restricted to that property for which the service was originally requested. (See Tariff Section G.3.)
- Tariff** – The operating policies, service rules, service extension policy, service rates, water use restriction policies, sample

application packet, and miscellaneous transaction forms adopted by the Board of Directors. A copy of this Board approved tariff is on file at the Corporation office and as required by law at the State office of the TCEQ.

Temporary Service – The classification assigned an applicant that is in the process of construction. This could also apply to service for uses other than permanent (agricultural, road construction, drilling, livestock, etc.). The Board will set the length of time associated with this classification. This classification will change to permanent service after requirements in Tariff Section E.1., E.2., E.3., and E.5. are met. Applicant must have paid a Service Investigation Fee.

Texas Commission on Environmental Quality (TCEQ) – State environmental agency. Provides synthesis and cohesion in environmental standards. The agency focuses mostly on promoting clean air and water and the safe management of waste in Texas. It also serves as a watchdog for the protection of the state’s natural resources.

Transferee – An Applicant receiving a Mustang Valley WSC Membership by legal means from a person or entity desiring to forfeit and transfer current rights of Membership to another person or entity. (See Tariff Section E.8.c., Miscellaneous Transaction Forms, Texas Water Code Section 67.016)

Transferor – A Member who transfers Membership by legal means to another person or entity desiring to qualify for service at a property for which the Membership is currently issued or to the Corporation. (Texas Water Code, Section 67.016)

Usage – Amount billed or to be collected based on the meter reading.

Water Conservation Penalty – A penalty that may be assessed under Section H of this Tariff to enforce Member water conservation practices during drought contingency or emergency water demand circumstances. (Texas Water Code Section 67.011 (b)).

SECTION D
GEOGRAPHIC AREA SERVED

This section includes an area map that shows the Corporation's Certificated Service Area.

CERTIFICATE OF CONVENIENCE AND NECESSITY

To Provide Water Service under Texas Water Code
and Texas Commission on Environmental Quality Substantive Rules

Certificate No. 11175

I. Certificate Holder:

Name: Mustang Valley Water Supply Corporation

Address: 301 N. 3rd St., Suite A, PO Box 6
Cranfills Gap, Texas 76637

II. General Description and Location of Service Area:

The Corporation shall serve the southwestern portion of Bosque County, Texas, including the communities of Mustang Valley, portions of Meridian, Norse and portions of Clifton, as well as the northeastern corner of Coryell County, Texas.

III. Certificate Maps:

The certificate holder is authorized to provide water service in the area identified on the Commission's official service area map, WRS-255, maintained in the offices of the Texas Commission on Environmental Quality, 12011 Park 35 Circle, Austin, Texas with all attendant privileges and obligations.

This certificate is issued under Application No. 35384-C and subject to the rules and orders of the Commission, the laws of the State of Texas, conditions contained herein and may be revoked for violations thereof. The certificate is valid until amended or revoked by the Commission.

Approved DLK
Revision Date: January 1, 2023

MUSTANG VALLEY WATER SUPPLY CORP.
IS AN EQUAL OPPORTUNITY PROVIDER.

Mustang Valley Water Supply Corporation Service Area

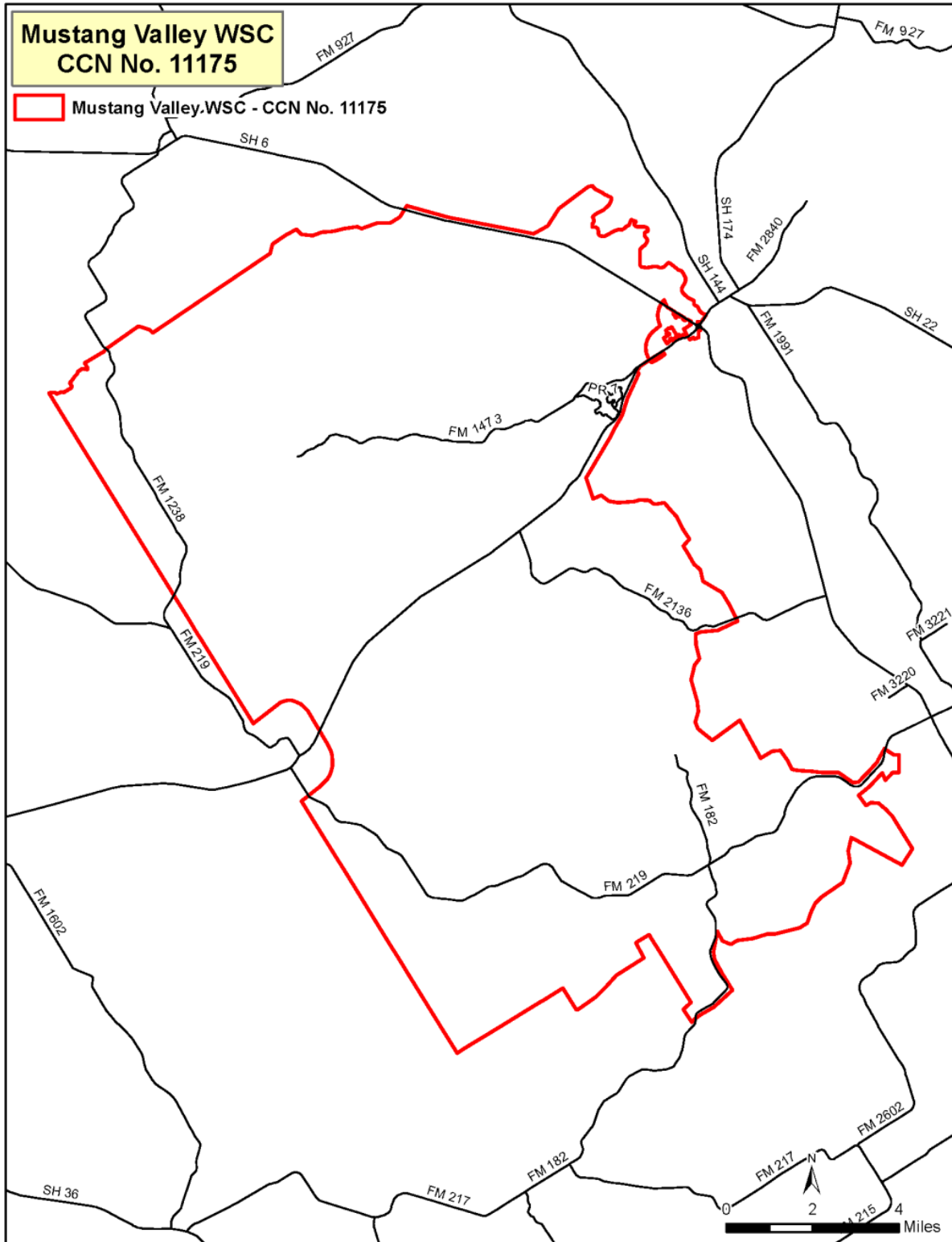

Approved DLK
Revision Date: January 1, 2023

MUSTANG VALLEY WATER SUPPLY CORP.
IS AN EQUAL OPPORTUNITY PROVIDER.

SECTION E
SERVICE RULES AND REGULATIONS

1. **Service Entitlement.** The Applicant(s) shall be considered qualified and entitled to water utility service when proper application has been made, terms and conditions of Service and Membership have been met and continue to be met, and all fees have been paid as prescribed. (30 TAC 291.85(a))
2. **Service Location and Classification.** For the purposes of this Tariff, service requested by the Applicant(s) shall be for real estate designated to receive the service provided by the Corporation. Service shall be through a meter located on that designated real estate unless otherwise approved by the board. Service shall be divided into the following two classes:
 - a. **Standard Service** is defined as service on a specific property designated to receive service on an existing pipeline where pipeline or service facility extensions are not required and special design and/or engineering considerations are not necessary. Typically, this will include 5/8" X 3/4" or 3/4" sized water meter services set on existing pipelines.
 - b. **Non-Standard Service** is defined as any service request which requires a larger meter service, service to a Master Metered Account (See Tariff Section E.6.), or an addition to the supply, storage and/or distribution system. The service requirements as prescribed by Section F of this Tariff shall be required of the Non-Standard Service Applicant prior to providing service.
3. **Service Requirements.** The Corporation's Service Application and Agreement Form shall be completed in full and signed by the Applicant(s). Where applicable in addition to the applicant, any other person sharing an ownership interest in and receiving service at that property shall sign the Service Application and Agreement Form; however, even if the spouse or other person sharing an ownership interest does not sign the Service Application and Agreement Form, they are still responsible for all terms set forth therein, and for any debt obligation related to the account. (See Sample Application RUS-TX Bulletin 1780-9 (Rev. 01/09))
 - a. A Right-of-Way Easement Form or other such easement forms required by the Corporation must be completed by the Applicant for the purpose of allowing future facility additions. (See Sample Application - RUS-TX Bulletin 1780-9 (Rev. 01/09), 30 TAC 290.47 Appendix C.)
NOTE: This requirement may be delayed for Non-Standard Service requests.
 - b. The Applicant shall provide proof of ownership to property for which service has been requested in a manner acceptable to the Corporation. Proof of ownership shall consist of the warranty deed or other properly recorded documentation of title to the real estate designated to receive service. (Texas Water Code Sections 67.016 (e), and 13.002 (11)).
 - c. On the request by the property owner or owner's authorized agent, the Corporation shall install individual meters owned by the Corporation in an apartment house, manufactured home rental community, multiple use facility, or condominium on which construction begins after January 1, 2003, unless the Corporation determines that installation of individual meters is not feasible. If the Corporation determines that installation of meters is not feasible, the property owner or manager shall install a plumbing system that is compatible with the installation of submeters or individual meters. The Corporation shall be entitled to the payment of costs, including the costs of individual meter installations, as provided in Section G. The cost of individual meter installations shall be prepaid by the property owner as well as the cost of any additional facilities or supply occasioned by the total water demand represented by full occupancy of the property, as determined under applicable provisions of Section F. It shall be the responsibility of the property owner to obtain the Memberships required for each individual meter.
 - d. Notice of application approval and costs of service determined by the Corporation shall be presented to the Applicant in writing and shall remain in effect for a period not to exceed thirty (30) days. After that time the Applicant must re-apply for service. (30 TAC 291.81(a)(1))
 - e. If the water main has been located in the public right-of-way and is adjacent to Applicant's property due to the current or previous landowner's refusal to grant easement to the Corporation for the purpose of installing the water main and appurtenances, and the Corporation has documentation of such refusal, the Applicant, prior to receiving the requested service, shall grant easement required under this Tariff and in addition to the normally required fees for new customer service, shall pay such sums as are reasonably necessary to cap the existing line in the right-of-way and construct the appropriate line or

Approved DLK
Revision Date: January 1, 2023

MUSTANG VALLEY WATER SUPPLY CORP.
IS AN EQUAL OPPORTUNITY PROVIDER.

lines within that easement for the Corporation's system-wide service. (See Miscellaneous Transaction Forms)

4. **Ownership of equipment.** All water meters and equipment and materials required to provide water service to the point of customer connection, water meter or service tap, is the property of the Corporation upon installation and shall be maintained by the water system only.
5. **Activation of Standard Service.**
 - a. **New Tap** - The Corporation shall charge a non-refundable service installation fee as required under Section G of this tariff. The service installation fee shall be quoted in writing to the Applicant. Any debt owed to the Corporation and all fees shall be paid or a deferred payment contract signed in advance of installation. (30 TAC 291.86 (a)(1)(A))
 - b. **Re-Service** – On property where service previously existed, the Corporation shall charge the Membership Fee (where the Membership Fee has been liquidated or refunded), reconnection costs, any debt owed to the Corporation if the applicant is the person that previously incurred those charges, seasonal reconnect fee as appropriate, and other applicable costs necessary to restore service.
 - c. **Performance of Work** – All tap and equipment installations specified by the Corporation shall be completed by the Corporation staff or designated representative after all application requirements have been met. The tap for a standard service request shall be completed within ten (10) working days whenever practicable. This time may be extended for installation of equipment for Non-Standard Service Request. (See Tariff Section F)
 - d. **Inspection of Customer Service Facilities** – The property of the Applicant/Member shall be inspected to ensure compliance with state required Minimum Acceptable Operating Practices For Public Drinking Water Systems as promulgated by the Texas Commission on Environmental Quality or successor agency. The customer must, at its expense, properly install, inspect, test, maintain and provide all required documentation of any approved backflow prevention device required by the Corporation. (30 TAC 290.46(j); Tariff Section I Service Application and Agreement)
6. **Activation of Non-Standard Service.** Activation of Non-Standard Service shall be conducted as prescribed by terms of Tariff Section F.
7. **Changes in Service Classification.** If at any time the Corporation determines that the customer service needs changed from those originally applied for to a different service classification and the Corporation determines that additional or different facilities are necessary to provide adequate service, the Corporation shall require the Applicant/Member to re-apply for service under the terms and conditions of this Tariff. Applicant/Members failing to comply with this provision shall be subject to the Disconnection with Notice Provisions in Tariff Section E.16.a.
8. **Membership.**
 - a. **Eligibility** – Eligibility for Membership shall not guarantee service to the Applicant or Transferee; however, qualification for service is a prerequisite to Membership eligibility for new Applicants or continued Membership for Transferees.
 - b. **Membership** – Upon qualification for service, qualification for Membership, payment of the required fees, and any debt owed to the Corporation, the Corporation shall certify the Applicant as a Member. The Membership shall entitle the Member to one (1) connection to the Corporation's water utility service and one (1) share of Corporation Stock. The Membership entitles the Member to one (1) vote in the election of directors and in such other matters requiring the approval of the Corporation's Members at any Annual or Special Membership Meeting of the Corporation as prescribed by the Corporation Bylaws. Ownership of more than one (1) Membership shall not authorize the Member to cast more than one (1) vote at any annual or special meeting. Each Membership and Stock thereby represented may be assigned to the specified parcel of land originally designated to receive service at the time of application. (Texas Water Code Section 67.016)

NOTE: In the event that the Corporation is conducting a potential Members survey for indications of interest in future service for the purpose of determining the feasibility of an initial construction or expansion project under RUS guidelines (See Sample Application Packet), regular application procedures may be modified. An Indication of Interest Fee shall be required prior to qualifications for receipt of service by the Applicant. If service is not provided within the scope of this project, Indication of Interest Fees shall

Approved DLK
Revision Date: January 1, 2023

MUSTANG VALLEY WATER SUPPLY CORP.
IS AN EQUAL OPPORTUNITY PROVIDER.

not be refunded.

In the event the applicant is in the process of construction the Membership will be considered TEMPORARY until such time as the final Customer Service Inspection is completed and the forms are returned as required. (See Tariff Section C, Section E Sub-Section 1. Service Entitlement)

- c. **Transfers of Membership.** – (Texas Water Code Section 67.016)
- (1) A Member is entitled to transfer Membership in the Corporation only under the following circumstances:
 - (a) The Membership is transferred by will to a person related to the Transferor within the second degree by consanguinity; or
 - (b) The Membership is transferred without compensation to a person related to the Transferor within the second degree by consanguinity; or
 - (c) The Membership is transferred without compensation or by sale to the Corporation; or
 - (d) The Membership is transferred as a part of the conveyance of real estate from which the Membership arose.
 - (2) In the event that Membership is transferred pursuant to the provisions of Tariff Section 9.c.(1) of this Section, such transfer shall not be completed or recorded on the books and records of the Corporation until such time as the transferor has provided satisfactory evidence to the Corporation of such transfer. A transfer of Membership shall be considered a new application for service and is not binding on the Corporation until such transfer has been approved as provided by Subsection 9.c.(3) of this Section.
 - (3) Qualifications for service upon transfer of Membership set forth in Tariff Section 8.c.(1) and 8.c.(2) of this Section shall be subject to approval of the Corporation and shall be recorded on the books and records of the Corporation only upon the following terms and conditions:
 - (a) The Transferee has completed the required Application Packet including granting the Corporation with a private utility easement on the form provided by the Corporation;
 - (b) The Membership has not been fully or partially liquidated; and
 - (c) The Transferee demonstrates satisfactory evidence of ownership of the property designated to receive service and from which the Membership originally arose.
 - (4) If the application packet and other information is not completed on the day transfer of Membership is requested the corporation will give the transferee written notice of 10 additional days to produce completed documentation to the corporation office. Service will be disconnected on the day following the 10th day according to disconnection with notice requirements. Additional time may be allowed at the directions of the manager or board.
- d. **Cancellation of Membership** – To keep a Membership in good standing, a Base Rate must be paid monthly to the Corporation, whether or not water is used. Failure to pay this monthly charge to the Corporation shall jeopardize the Member’s Membership standing and give rise to liquidation of the Membership Fee and forfeiture of the Membership. A Member may be relieved of this obligation to pay by surrendering the Membership, properly documented, to the Corporation. The Member shall also complete a Service Discontinuance Request Form prior to termination of service. (See Misc. Transaction Forms.) However, a Member is not relieved of any obligations incurred prior to the date of surrender of a properly endorsed Membership prior to termination of service. Rights to future service at this tap shall be extended on an as-available basis and subject to the terms of Tariff Section E.5.b Activation of Service (Texas Water Code Section 67.016)
- e. **Liquidation Due To Delinquency** – When the amount of the delinquent charges owed by the Member equals the Membership Fee, the Membership Fee shall be liquidated and the Membership canceled and transferred back to the Corporation. In the event the Member leaves a balance due on an account guaranteed under the terms of a Service Application and Agreement, and the delinquent Member owns more than one Membership, the Corporation may liquidate as many of the Member Guarantor’s Membership Fees as necessary to satisfy the balance due the Corporation, provided proper notice has been given. (See Tariff Section E.16.) The Corporation shall collect any remaining account balances by initiation of legal action. Re-instatement of service shall be subject to the terms in Tariff Section E.5.b.)
- f. **Cancellation Due To Policy Non-Compliance** – The Corporation may cancel a Membership anytime a Member fails to comply with policies of the Corporation, including but not limited to Member’s failure to provide proof of ownership of the property from which the Membership arose. (Texas Water Code Section

67.016

g. Re-assignment of Canceled Membership

- (1) The Corporation, upon cancellation of Membership under the provisions of this Tariff, may re-assign the canceled Membership to a person or entity that has legal title to the real estate from which the canceled Membership arose and for which water service is requested (Texas Water Code Section 67.016). Membership will not be re-assigned unless the person or entity that has legal title to the real estate has complied with the corporation's current rates, charges, and conditions of service, including current Membership fee, set forth in the tariff and service application package.
- (2) The Corporation shall reassign a canceled Membership to a person or entity that acquires the real estate from which the Membership arose through judicial or nonjudicial foreclosure. The Corporation will require proof of ownership resulting from the foreclosure and compliance with the corporation's current rates, charges, and conditions of service, including current Membership fee, set forth in the tariff and service application package. In the event of foreclosure by a mortgage institution, the Corporation may allow a property management company to acquire the Membership if the management company provides written documentation showing that the management company is legally responsible for the management of the property and it is not feasible for the mortgage institution to be the Member.

h. Mortgaging of Memberships – Nothing herein shall preclude a Member from mortgaging his/her Membership. However, notification to the holder of any security interest (mortgagee/lien-holder) of account status of Member/mortgagor will be provided only upon satisfactory completion of requirements for such conditions under the Membership Mortgage Agreement (See Miscellaneous Transaction Forms). Prior to the cancellation of any Membership as provided under Tariff Section E.9.d. (Cancellation of Membership), the Corporation will notify the holder of any security interest in the Membership. The holder of the security interest also must hold a security interest in the real property at which water service is provided under the Membership. The Corporation may transfer the Membership to the holder of such security interest in lieu of cancellation, provided the holder of the security interest pays in full all delinquent and unpaid obligations and provided further that the holder of the security interest has secured title to the real property from which the Membership arose. The Corporation may withhold cancellation of a Membership pending the resolution of any foreclosure proceedings or similar legal proceedings by the holder of the security interest.

i. Cancellation and Re-Assignment of Membership as a Result of Bankruptcy Proceedings – Upon notice of the filing of a petition in bankruptcy, the Corporation may require the posting of a deposit or other form of security, acceptable to the Corporation, as a condition for continuing utility service. Unless special circumstances require otherwise, the amount of security shall equal the amount of charges for the month of greatest use during the preceding 12 months. The Corporation shall not require the payment of any security prior to the expiration of 20 days following the date on which the petition is filed. Failure to provide this security by the date specified by the Corporation may result in termination of service according to the Disconnection with Notice Provisions of Tariff Section E.16. with a copy of the notice to the bankruptcy Trustee.

j. Cancellation and Re-Assignment of Membership as a Result of Divorce (or Dissolution of Joint Tenancy) – The Corporation shall transfer the Membership to a spouse (or joint tenant) who has been awarded the property designated to receive service. The Corporation must be provided adequate documentation of the ownership rights of the spouse (or joint tenant) requesting transfer, such as final divorce decree, temporary court order, or agreement. In no event shall any Membership(s) be transferred if the transferee does not otherwise meet the qualifications for Membership and for service.

9. Owners and Renters. Any Member having complied with the requirements of this Tariff, renting or leasing property designated to receive service according to the terms of this tariff to other parties, is responsible for all charges due the Corporation. The Membership for rental or leased properties shall be in the name of the owner of the property as required by this Tariff. The Corporation may bill the renter or lessee for utility service (at Member Request) as a third party, but the Member is fully responsible for any and all unpaid bills left by the renter/lessee. The owner shall be required to sign an Alternate Billing Agreement if the owner requests that the tenant be billed for utility service. (See Miscellaneous Transaction Forms.) The Member shall take responsibility for any necessary deposits from the renter/lessee to ensure payment of a past due bill. The Corporation will notify the Member of the renter's past due payment status. Such notification will be subject to a service charge (See Miscellaneous Transaction Forms).

If at any time the Member requests that Membership be canceled thereby discontinuing service to an occupied rental property, the Corporation shall provide written notice to the tenant(s) a minimum of five (5) days prior to the scheduled disconnection date.

10. **Denial of Service.** The Corporation may deny service for any of the following reasons:
- Failure of the Applicant or Transferee to complete all application requirements, including granting an easement, completing all forms, and paying all required fees and charges;
 - Failure of the Applicant or Transferee to comply with rules, regulations, policies, and bylaws of the Corporation;
 - Existence of a hazardous condition at the Applicant's property which would jeopardize the welfare of the Members/Users of the Corporation upon connection;
 - Failure of Applicant or Transferee to provide representatives or employees of the Corporation reasonable access to property, for which service has been requested;
 - Failure of Applicant or Transferee to comply with all governmental rules and regulations of the Corporation's tariff on file with the state regulatory agency governing the service applied for by the Applicant;
 - Failure of Applicant or Transferee to provide proof of ownership, to the satisfaction of the Corporation, of property for which the tap has been requested;
 - Applicant's service facilities are known to be inadequate or of such character that satisfactory service cannot be provided;
 - Failure of the Applicant or Transferee to pay any previous outstanding delinquent account(s) in full. This could be delinquencies resulting from the same account location or other service location(s) within the system where the Applicant or Transferee received service. (Also see Tariff Section E.8.)
11. **Applicant's or Transferee's Recourse.** In the event the Corporation refuses to serve an Applicant under the provisions of these rules, the Corporation must notify the Applicant, in writing, on the basis of its refusal. The Applicant may file for an appeal, in writing, with the Board of Directors of the Corporation.
12. **Insufficient Grounds for Refusal of Service.** The following shall not constitute sufficient cause for the refusal of service to an Applicant:
- Delinquency in payment for service by a previous Member or occupant of the premises to be served;
 - Failure to pay a bill to correct previous underbilling due to misapplication of rates more than six (6) months prior to the date of application;
 - Violation of the Corporation's rules pertaining to operation of non-standard equipment or unauthorized attachments which interferes with the service of others, unless the customer has first been notified and been afforded reasonable opportunity to comply with said requirements;
 - Failure to pay a bill of another Member or customer as guarantor thereof unless the guarantee was made in writing to the Corporation as a condition precedent to service;
 - Failure to pay the bill of another Member or customer at the same address except where the change of customer identity is made to avoid or evade payment of a utility bill.
13. **Deferred Payment Agreement.** The Corporation may offer a deferred payment plan to a Member or rental tenant who cannot pay an outstanding balance in full and is willing to pay the balance in reasonable installments as determined by the Corporation, including any Late Penalty Fees or interest on the monthly balance to be determined as per agreement. (See Miscellaneous Transaction Forms) Failure to make required and timely payments as provided in any deferred payment agreement will void that agreement and service will be discontinued. The Corporation may consider another deferred payment agreement provided payments will be made by automatic bank draft or credit/debit card. Non-payment of any amount under an additional deferred payment agreement will cause service to be disconnected immediately and service will not be restored until the account is paid in full and all other charges resulting from the disconnection of service are fully paid. In the event the requestor is a tenant of rental property the Corporation shall notify the owner/Member of the deferred payment agreement.
14. **Charge Distribution and Payment Application.**
- The Base Rate** is for the billing period from the first day of the month to the first day of the following month. Billings for this amount shall be mailed on or about the 1st of the month following the month for which this charge is due. All services shall be subject to this charge whether or not the service is in use by the Member.

- b. **Gallonge Charge** shall be billed at the rate specified in Section G and billing shall be calculated for actual gallons of water used. Water charges are based on monthly meter readings and are calculated from reading date to reading date. Readings used in all billing calculations shall be used from AMR (Automatic Meter Reading Device) data collected.
 - c. **Posting of Payments.** All payments shall be posted against previous balances and late fees prior to posting against current billings.
 - d. **Forms of Payment.** The Corporation will accept the following forms of payment: cash, personal check, bank check, cashier's check, money order, or through the third party payment processor. The Corporation will not accept two-party checks, pay checks, or any other instrument of payment that is not made out to the Corporation. The Corporation reserves the right to require exact change and may refuse to accept payments made using more than \$1.00 in coins.
15. **Due Dates, Delinquent Bills, and Service Disconnection Date.**
- a. The Corporation shall mail all bills on or about the first of the month. All bills are considered the responsibility of each person signing the Service Application and Agreement Form. All bills shall be due and payable upon receipt and are past due beyond the date indicated on the bill (allowing approximately fifteen (15) days to pay), after which time a penalty shall be applied as described in Tariff Section G. The time for payment by a political subdivision may be different than the regular due date. (See Texas Government Code 2251.021) A bill is delinquent if not paid on or before the past due date. Payments made by mail will be considered late if postmarked after the past due date. A 15 day grace period will then be allowed for delayed payments prior to mailing of final notices. Final notices shall be mailed allowing ten (10) additional days for payment prior to disconnection. The ten (10) additional days shall begin on the day the final notice is deposited with the U.S. Postal Service with sufficient postage. If the past due date for the regular or final billing is on a weekend or holiday, the past due date for payment purposes shall be the next day the Corporation office is open for business after said weekend or holiday. For all disputed payment deadlines, the date postmarked on each bill will determine the beginning of each billing cycle or final notice mailings.
 - b. The Board of Directors or general manager may elect to not charge a late fee or disconnect fee in accordance with this Tariff during or after the occurrence of a natural disaster or other incident that impacts the property of Members or interrupts the management and operation of the system.
 - c. Upon written request, any residential customer 60 years of age or older who occupies the entire premises of a dwelling receiving water utility service from the Corporation shall receive extension of the past due date, without penalty. The extension shall not exceed 10 days beyond the usual 15 day payment period for a total of no more than 25 days from the date the bill is issued. The request may specify extension of the late payment periods for current and subsequent billings. (Texas Utilities Code Sections 182.001 - 182.005) If this request originates from a tenant at a rental property the owner/Member will be notified in writing of any extension request.
 - d. All insufficient fund checks, accounts closed or money orders that have had a "stop payment order" issued for payment of a water bill will be deemed delinquent as if no payment was received and the meter is subject to disconnection with notice on the regular disconnection day.
16. **Rules for Disconnection of Service.** The following describes the rules and conditions for disconnection of service. Notwithstanding any language to the contrary in the Service Application and Agreement Form, the Corporation may only discontinue service for the reasons set forth in this Section.
- a. **Disconnection with Notice** – Water utility service may be disconnected for any of the following reasons after proper notification has been given.
 - (1) Returned Checks – The Corporation shall mail, via the U.S. Postal Service, a notice requiring redemption of the returned instrument within ten (10) days of the date of the notice to be made in the Corporation office. Redemption of the returned instrument shall be made by cash, money order, or certified check. Failure to meet these terms shall initiate disconnection of service. (See Miscellaneous Transaction Forms) Any such instruments returned as insufficient or non-negotiable for any reason for any two billing periods within a 12-month period shall be considered evidence of bad credit risk by the Corporation. The Member/Customer in violation shall be placed on a "cash-only" basis for a period of 12 months. NOTE: No personal check accepted.
 - (2) Failure to pay a delinquent account for utility service, failure to timely provide a deposit or other security under Tariff Section E.8.h., or failure to comply with the terms of a deferred payment

- agreement (Miscellaneous Transaction Forms);
- (3) Violation of the Corporation's rules pertaining to the use of service in a manner which interferes with the service of others or the operation of non-standard equipment if a reasonable attempt has been made to notify the Member and the Member is provided with a reasonable opportunity to remedy the situation;
 - (4) Failure of the Member to comply with the terms of the Corporation's Service Agreement, Tariff (including, where appropriate, Section H), Bylaws, or Special Contract provided that the Corporation has given notice of said failure to comply, and Member has failed to comply within a specified amount of time after notification.
 - (5) Failure to provide access or hindering access to the meter under the terms of this Tariff or to property at which water service is received when there is reason to believe that a hazardous condition or policy violation exists for which access is necessary to verify. Conditions that may hinder access include, but are not limited to, fences with locked gates, vehicles or objects placed on top of meters or meter boxes, unrestrained animals, and excessive plant growth surrounding meter boxes.
 - (6) Misrepresentation by any Applicant or Transferee of any fact on any form, document, or other agreement required to be executed by the Corporation.
 - (7) Failure of Member to re-apply for service upon notification by the Corporation that Member no longer meets the terms of the service classification originally applied for under the original service application.
 - (8) Cancellation of Membership by Member on an account that the Member holds for water service to the Member's renter/lessee, even if the renter/lessee has kept the account balance current under an Alternate Billing Agreement. NOTE: The cancellation of Membership must be in writing and signed by the Member. CORPORATION ASSUMES NO LIABILITY TO RENTER/LESSEE; MEMBER IS SOLELY RESPONSIBLE FOR COMPLIANCE WITH, AND LIABILITY UNDER ANY FEDERAL, STATE OR LOCAL LAW CREATING OR PROTECTING RIGHTS OF RENTERS/LESSEES.)
 - (9) Violation of any applicable regulation pertaining to on-site sewage disposal systems if the Corporation has been requested in writing to disconnect service by the TCEQ or the TCEQ's designated representative under Chapter 366 of the Texas Health and Safety Code.
 - (10) Failure to pay charges arising from service trip fee as defined in Tariff Section G.13.
 - (11) Failure by a Member to pay for all repair or replacement costs resulting from the Member damaging system facilities including, but not limited to water or lines, service taps, meter boxes, valves, or meters by engaging in activities such as property excavations, installment of a driveway or roadway requiring encasements, lowering or re-routing of lines or system components, or by any other action. The Corporation will provide the Member with notice detailing the extent of the damage, the location of the damage, the cost of repair, and whether the damage occurred on private property or on a public right-of-way. Failure to pay the cost of repair or replacement will result in the Member's service being disconnected in accordance with the Disconnection with Notice Provisions in this Section. Service will remain disconnected until payment is received or an acceptable payment plan is approved.
 - (12) Failure to disconnect or secure additional service tap(s) for an RV or other service connection (See Tariff Section E.24.) after notification by the Corporation of violation of the Prohibition of Multiple Connections.
- b. **Disconnection Without Notice** – Water utility service may be disconnected without notice for any of the following conditions:
- (1) A known dangerous or hazardous condition exists for which service may remain disconnected for as long as the condition exists, including but not limited to a public health nuisance as defined in Texas Health and Safety Code Sections 341.011 or 343.011. If there is reason to believe a dangerous or hazardous condition exists, the Corporation may require a customer service inspection (CSI) to verify the hazardous condition and may notify the local county health office. The Corporation will disconnect without notice if the Member refuses to allow access for the purpose of confirming the existence of such condition and/or removing the dangerous or hazardous condition (30 TAC 290.46(i) and 290.46(j)). Service will be restored when a CSI confirms no health hazard exists, the health hazard has been removed or repaired, or the health hazard has been isolated from the Corporation's water system by the installation of a backflow prevention device. Should the corporation confirm the existence of a dangerous or hazardous condition, Member will be

responsible for all costs associated with inspections and corrections.

- (2) A line leak on the Member's side of the meter is considered a potentially hazardous condition under Tariff Section E.16.b.1. If the Corporation confirms the line leak has created a hazardous condition, the Corporation will provide the Member up to five (5) business days, or another time period determined reasonable under the circumstances, to repair the line prior to disconnection of service. Should a dangerous or hazardous condition be confirmed, the member will be responsible for all costs associated with inspections and corrections.
 - (3) Service is connected without authority by a person who has not made application for service or who has reconnected service without authority following termination of service for nonpayment; and
 - (4) In instances of tampering with the Corporation's meter or equipment, by-passing the meter or equipment, or other diversion of water service.
- NOTE:** Where reasonable, given the nature of the reason for disconnection, a written statement providing notice of disconnection and the reason therefore shall be posted at the place of common entry or upon the front door of each affected residential unit as soon as possible after service has been disconnected.
- c. **Disconnection Prohibited** – Utility service may not be disconnected for any of the following reasons:
 - (1) Failure of the Member to pay for merchandise or charges for non-utility service provided by the Corporation, unless an agreement exists between the Applicant and the Corporation whereby the Member guarantees payment of non-utility service as a condition of service;
 - (2) Failure of the Member to pay the account of another Member as guarantor thereof, unless the Corporation has in writing the guarantee as a condition precedent to service;
 - (3) Failure of the Member to pay charges arising from an underbilling due to any faulty metering, unless the meter has been tampered with or unless such underbilling charges are due under the Inoperative Meters in Tariff Section E.20.
 - (4) Failure of the Member to pay an estimated bill other than a bill rendered pursuant to an approved meter reading plan, unless the Corporation is unable to read the meter due to circumstances beyond its control.
 - d. **Disconnection on Holidays and Weekends** – Unless a dangerous condition exists or the Member requests disconnection, service shall not be disconnected on a day, or on a day preceding a day, when personnel of the Corporation are not available to the public for the purpose of making collections and reconnecting service.
 - e. **Disconnection Due to Utility Abandonment** – The Corporation may not abandon a Member or a Certificated Service Area without written notice to its Members and all similar neighboring utilities and approval from the Texas Commission on Environmental Quality.
 - f. **Disconnection for Ill Customers** – The Corporation may not discontinue service to a delinquent residential Member or tenant under an alternative billing agreement permanently residing in an individually metered dwelling unit when that Member or tenant establishes that discontinuance of service will result in some person at that residence becoming seriously ill or more seriously ill if service is discontinued. To avoid disconnection under these circumstances, the Member or tenant must provide a written statement from a physician to the Corporation prior to the stated date of disconnection. Service may be disconnected in accordance with Subsection (a) of this Section if the next month's bill and the past due bill are not paid by the due date of the next month's bill, unless the Member or tenant enters into a Deferred Payment Agreement. The Corporation shall provide notice to an owner of rental property in the event a tenant requests service not be discontinued due to illness as per this subsection.
 - g. **Disconnection of Master-Metered Accounts** – When a bill for water utility services is delinquent for a master-metered service complex (defined as a complex in which a single meter serves two (2) or more residential dwelling units), the following shall apply:
 - (1) The Corporation shall send a notice to the Member as required. This notice shall also inform the Member that notice of possible disconnection will be provided to the tenants of the service complex in five (5) days if payment is not rendered before that time.
 - (2) At least five (5) days after providing notice to the Member and at least five (5) days prior to disconnection, the Corporation shall post notices, stating "Termination Notice" in public areas of the service complex notifying the residents of the scheduled date for disconnection of service.
 - (3) The tenants may pay the Corporation for any delinquent bill in behalf of the owner to avert disconnection or to reconnect service to the complex.

- h. **Disconnection of Temporary Service** – When an applicant with a Temporary service fails to comply with the conditions stated in the Service Application and Agreement Form or other rules of this Tariff service may be terminated with notice.
17. **Billing Cycle Changes.** The Corporation reserves the right to change its billing cycles if the workload requires such practice. After a billing period has been changed, the billings shall be sent on the new change date unless otherwise determined by the Corporation.
18. **Back-billing.** The Corporation may back-bill a Member for up to one (1) year for meter error, misapplied meter multiplier, incorrect meter readings, or error in computing a Member’s bill. Failure to pay the most recent six (6) months billing will result in disconnection of service.
19. **Disputed Bills.** In the event of a dispute between the Member and the Corporation regarding any bill, the Corporation shall make and conduct an investigation as required by the particular case, and report the results in writing thereof to the Member. All disputes under this Subsection must be submitted to the Corporation, in writing, prior to the due date posted on said bill.
20. **Inoperative Meters.** Water meters found inoperative will be repaired or replaced within a reasonable time. If a meter is found not to register for any period, unless by-passed or tampered with, the Corporation shall make a charge for units used, but not metered, for a period not to exceed six (6) months, based on amounts used under similar conditions during the period preceding or subsequent thereto, or during corresponding periods in previous years.
21. **Bill Adjustment.**
- a. **Due to Meter Error:** The Corporation shall test any Member’s meter upon written request of the Member. In the event the meter tests within the accuracy standards of The American Water Works Association, a test fee as prescribed in Tariff Section G.17. shall be imposed. In the event the test results indicate that the meter is faulty or inaccurate, the test fee shall be waived, the meter shall be calibrated or replaced, and a billing adjustment may be made as far back as six (6) months. The billing adjustment shall be made to the degree of the meter’s inaccuracy as determined by the test. The Member shall complete a Meter Test Request Form prior to the test. (See Misc. Transaction Forms.)
 - b. **Due to Estimated Billing:** If the Corporation has estimated usage because the Corporation is unable to access the meter due to circumstances beyond the Corporation’s control, such as a natural disaster; or because access is hindered or denied by a Member, the Corporation shall adjust the bill once access has been regained and actual usage is determined.
22. **Meter Tampering and Damage to Property.**
- a. For purposes of this Section, the term “Tampering” shall mean meter-tampering, by-passing, or diversion of the Corporation’s service equipment, or other instances of diversion, including:
 - (1) Removing a locking or shut-off device used by the Corporation to discontinue service,
 - (2) Physically disorienting the meter,
 - (3) Attaching objects to the meter to divert service or to by-pass,
 - (4) Inserting objects into the meter,
 - (5) Other electrical and mechanical means of tampering with, by-passing, or diverting service,
 - (6) Connection or reconnection of service without Corporation authorization,
 - (7) Connection into the service line of adjacent customers of the Corporation, and
 - (8) Preventing the supply from being correctly registered by a metering device due to adjusting the valve so that flow is reduced below metering capability.

The burden of proof of Tampering is on the Corporation. Photographic evidence or any other reliable and credible evidence may be used; however, any evidence shall be accompanied by a sworn affidavit by the Corporation’s staff when any action regarding Tampering is initiated. A court finding of Tampering may be used instead of photographic or other evidence, if applicable. Unauthorized users of services of the Corporation shall be prosecuted to the extent allowed by law under the Texas Penal Code Sections 28.03 and 12.21 and 12.22.
 - b. If the Corporation determines under subsection (a) that Tampering has occurred, the Corporation shall disconnect service without notice as set forth in Tariff Section E.16.b.(4) and charge the person who committed the Tampering the total actual loss to the Corporation, including the cost of repairs,

replacement of damaged facilities, and lost water revenues.

- c. A person who otherwise destroys, defaces damages or interferes with Corporation property will be charged the total actual loss to the Corporation including but not limited to the cost of repairs, replacement of damaged facilities, and lost water revenues. The Corporation also will prosecute the offending party to the extent allowed under law pursuant to Texas Water Code Section 49.228 and other applicable laws.
- d. In addition to actual damages charged under subsection (b), the Corporation may assess a penalty against the offending party. The penalty shall not exceed six (6) times the Base Rate.

NOTE: For purposes of this section, “offending party” means the person who committed the Tampering or damaged the property.

23. **Meter Relocation.** Relocation of services shall be allowed by the Corporation provided that:

- a. The relocation is limited to the existing property designated to receive service;
- b. A current easement for the proposed location has been granted to the Corporation; and
- c. The Member pays the actual cost of relocation plus administrative fees.

24. **Prohibition of Multiple Connections to a Single Tap.**

- a. No more than one (1) residential, commercial, or industrial service connection is allowed per meter. The Corporation may consider allowing an apartment building or mobile home/RV park to apply as a “Master Metered Account” and have a single meter tap. (See Tariff Section E.25.) If the Corporation has sufficient reason to believe a Multiple Connection exists, the Corporation shall discontinue service under the Disconnection with Notice provisions of this Tariff for a first violation and for subsequent violations, service will be disconnected without notice in accordance with Tariff Section E.16.b. (See Sample Application Packet RUS-TX Bulletin 1780-9 (Rev. 01/09))
- b. For purposes of this section, the following definitions shall apply:
 - (1) A “multiple connection” is the connection to any portion of a Member’s water system that is connected to a primary delivery point already servicing one residence, one commercial or industrial facility or a water line serving another residence or commercial or industrial facility. Water lines to outbuildings, barns or other accessory structures shall not be considered a multiple connection if: (i) those structures are located on the same tract as the primary delivery point and (ii) such structures are not used as a residence or as a commercial or industrial facility.
 - (2) A “primary delivery point” shall mean the physical location of a meter that is installed in accordance with this Tariff and applicable law and which provides water service to the residence or commercial or industrial facility of a Member.
 - (3) A “residence” shall mean any structure which is being used for human habitation, which may include kitchen and bathroom facilities or other evidence of habitation as defined by the Corporation.
 - (4) “Commercial” facility shall mean any structure or combination of structures at which any business, trade, occupation, profession, or other commercial activity is conducted. A business conducted within a Member’s residence or property that does not require water in addition to that provided to the Member’s residence shall not be considered a separate commercial facility.
- c. The corporation agrees to allow Members in good standing to share water usage with a visitor on their property with a recreation vehicle (RV), travel trailer, or in a non-commercial use guest house for a period of no longer than 90 consecutive days. If the recreation vehicle/travel trailer/guest house is being used for a permanent residence, this Tariff requires that an additional meter installation and Membership be purchased. If the Member routinely has more than one visitor at a time with recreation vehicles or travel trailers or has multiple visitors throughout the year, the corporation may require that a second or additional meter(s) be purchased. The corporation has the right to refuse or deny the shared usage for any reason. The corporation also has the right to require a Customer Service Inspection of the premises for any potential cross-contamination issues as outlined in the CSI requirements, and to ensure that the meter is properly sized for the additional usage at the time of total peak water demand. These requirements pertain to visitors ONLY. No commercial usage where fees for water are charged is allowed. If a Member is found to violate these conditions, the Member will be sent a letter of notice stating that water service will be cut off in ten days if the situation is not corrected.

25. **Master Metered Account Regulations.** An apartment building, condominium, manufactured housing (modular, mobile or RV) community, business center or other similar type enterprise may be considered by the Corporation to be a single commercial facility if the owner applies for a meter as a “master metered account” and complies

with the requirements set forth in TCEQ rules, this Tariff and applicable law. The Corporation may allow master metering service to these facilities at an Applicant’s request.

26. Member’s Responsibility.

- a. The Member shall provide access to the meter or location as per the easement and service agreement. If access to the meter is hindered or denied preventing the reading of the meter, an estimated bill shall be rendered to the Member for the month; and a notice shall be sent to the effect that access could not be gained. If access is denied for three (3) consecutive months after proper notification to the Member, then service shall be discontinued and the meter removed with no further notice. Conditions that may hinder access include, but are not limited to, fences with locked gates, vehicles or objects placed on top of meters or meter boxes, and unrestrained animals.
- b. The Member shall be responsible for compliance with all utility, local, and state codes, requirements, and regulations concerning on-site service and plumbing facilities.
 - (1) All water connections shall be designed to ensure against on-site sewage contamination, back-flow or siphonage into the Corporation’s water supply. In particular, livestock water troughs shall be plumbed above the top of the trough with air space between the discharge and the water level in the trough. (30 TAC 290.46, Texas Health & Safety Code Chapter 366.
 - (2) The use of pipe and pipe fittings that contain more than 0.25% lead or solder and flux that contain more than 0.2% lead is prohibited for any plumbing installation or repair of any residential or non-residential facility providing water for human consumption and connected to the Corporation’s facilities. Customer service pipelines shall be installed by the applicant. (30 TAC 290.46). Service shall be discontinued without further notice when installations of new facilities or repair of existing facilities are found to be in violation of this regulation until such time as the violation is corrected.
- c. A Member owning more than one (1) Membership shall keep all payments current on all accounts. Failure to maintain current status on all accounts shall be enforceable as per the Service Application and Agreement executed by the Member.
- d. The Corporation’s ownership and maintenance responsibility of water supply and metering equipment shall end at the meter. Therefore, all water usage registering upon and/or damages occurring to the metering equipment owned and maintained by the Corporation shall be subject to charges as determined by the Corporation’s Tariff as amended from time to time by the Board of Directors.
- e. The Corporation shall require each Member to have a cut-off valve within two feet of the meter on the Member’s side of the meter for purposes of isolating the Member’s service pipeline and plumbing facilities from the Corporation’s water pressure. The valve shall meet AWWA standards (a ball valve is preferred). The Member’s use of the Corporation’s curb stop or other similar valve for such purposes is prohibited. Any damage to the Corporation’s equipment shall be subject to service charges.
- f. As a one-time courtesy at the time of a new meter installation, the corporation will install a pressure regulating valve, and cutoff valve for the Member’s convenience. However, the corporation shall have no responsibility for maintenance and/or replacement of any equipment on the customer’s side of the meter after the initial meter installation.
- g. The Member is required to notify the Corporation office, the Lone Star 811 system, or other such service as may be designated by the Corporation 48 hours prior to digging or excavation activities along or near water lines and appurtenances.
- h. The sketch below defines the standard meter installation and attendant equipment supply and installation requirements as specified in Tariff Section E.26.e. above. At the time of a new meter installation, the corporation will install a pressure regulating valve and cutoff valve for the Member’s convenience. However, the corporation shall have no responsibility for maintenance and/or replacement of either the pressure regulator and/or cutoff valve.

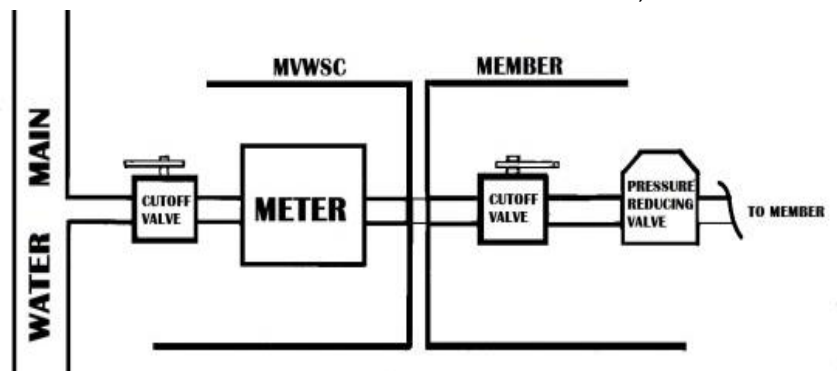

Approved DLK
 Revision Date: January 1, 2023

MUSTANG VALLEY WATER SUPPLY CORP.
 IS AN EQUAL OPPORTUNITY PROVIDER.

SECTION F
DEVELOPER, SUBDIVISION AND NON-STANDARD SERVICE REQUIREMENTS

PART I General Requirements.

This section details the requirements for all types of non-standard service requests.

1. **Purpose.** It is the purpose of this Section to define the process by which the specific terms and conditions for service to subdivisions and other kinds of Non-Standard Service are determined, including the Non-Standard Service Applicant's and the Corporation's respective costs.

For purposes of this Section, the term "Applicant" shall refer to the individual or entity that desires to secure Non-Standard Service from the Corporation. The Applicant must be the same person or entity that is authorized to enter into a contract with the Corporation setting forth the terms and conditions pursuant to which Non-Standard Service will be furnished to the property. In most cases, the Applicant shall be the owner of real property for which Non-Standard Service is sought. In the event that the Applicant is other than the owner of real property, the Applicant must furnish evidence to the Corporation that it is authorized to request Non-Standard Service on behalf of such owner, or that it otherwise has authority to request Non-Standard Service for the real property.

2. **Application of Rules.** This Section is applicable to subdivisions, additions to subdivisions, developments, or whenever additional service facilities are required for a single tract of property. Examples of non-standard services for a single tract of land can include, but are not limited to, road bores, extensions to the distribution system, service lines exceeding 3/4" diameter and service lines exceeding 5 (five) feet. Non-residential or residential service applications requiring a larger sized meter typically will be considered non-standard. For the purposes of this Tariff, Applications subject to this Section shall be defined as Non-Standard. This Section may be altered or suspended for planned facility expansions when the Corporation extends its indebtedness. The Board of Directors of the Corporation or their designee shall interpret on an individual basis whether or not the Applicant's service request shall be subject to all or part of the conditions of this Section.

This Section sets forth the general terms and conditions pursuant to which the Corporation will process Non-Standard Service Requests. The specific terms and conditions pursuant to which the Corporation will provide non-standard service in response to any request will depend upon the nature of such request and may be set forth in a legally enforceable, contractual agreement to be entered into by the Corporation and the service Applicant. The agreement may not contain any terms or conditions that conflict with this Section.

3. **Non-Standard Service Application.** The Applicant shall meet the following requirements prior to the initiation of a Non-Standard Service Contract by the Corporation:
 - a. The Applicant shall provide the Corporation a completed Non-Standard Service Application (See Section I of this Tariff). The Applicant shall specify any Special Service Needs, such as large meter size, size of subdivision or multi-use facility.
 - b. A final plat (See Tariff Definition Section- Final Plat) approved by the Corporation must accompany the Application showing the Applicant's requested service area. The plat must be approved by all governmental authorities exercising jurisdiction over lot sizes, sewage control, drainage, right-of-way, and other service facilities. Plans, specifications, and special requirements of such governmental authorities shall be submitted with the plat. Applicants for single taps involving extension or upsizing of facilities shall be required to submit maps or plans detailing the location of the requested extension and details of demand requirements.
NOTE: It is the responsibility of the Applicant to secure all necessary approvals of the subdivision once an Agreement is in place between the Corporation and the Applicant.
 - c. A Non-Standard Service Investigation Fee shall be paid to the Corporation in accordance with the requirements of Section G of this Tariff for purposes of paying initial administrative, legal, and engineering fees. The Corporation shall refund any balance that remains after it has completed its service investigation, and has completed all legal and engineering services associated with processing a request. In the event such a fee is not sufficient to pay all expenses incurred by the Corporation, the Applicant shall pay to the Corporation upon the Corporation's request all additional expenses that have been, or will be incurred by the Corporation and Corporation shall have no obligation to complete processing of the Application until all remaining

expenses have been paid.

- d. If after the service investigation has been completed, the Corporation determines that the Applicant's service request is for property located, in whole or in part, outside the area described in the Corporation's Certificate of Convenience and Necessity, service may be extended provided that:
- (1) The service location is not within another retail Corporation's Certificate of Convenience and Necessity; and
 - (2) The Corporation's Certificate of Convenience and Necessity shall be amended to include the entirety of Applicant's property for which service is requested. Applicant shall pay all costs incurred by Corporation in amending its CCN, including but not limited to engineering and professional fees. If the service location is contiguous to or within one-fourth (1/4) mile of Corporation's Certificate of Convenience and Necessity, Corporation may extend service prior to completing the amendment to its CCN, but will do so only upon Applicant's legally enforceable agreement to fully support such amendment (including but not limited to payment of all professional fees, including legal, surveying and engineering fees incurred by Corporation in securing the amendment).
4. **Design.** The Corporation shall approve the design requirements of the Applicant's required facilities prior to initiation of a Non-Standard Service Contract in accordance with the following schedule:
- a. The Corporation's engineer shall design, or review and approve plans for, all on-site and off-site service facilities for the Applicant's requested service within the Corporation's specifications, incorporating any applicable municipal or other governmental codes and specifications.
 - b. The engineer's fees shall be paid out of the Non-Standard Service Investigation Fee under Tariff Section F 3.
 - c. The engineer shall submit to the Corporation a set of detailed plans, specifications, and cost estimates for the project.
 - d. The Corporation's engineer shall ensure that all facilities for any Applicant meet the demand for service as platted and/or requested in the plans or plat submitted in Applicant's application for service. The Corporation reserves the right to upgrade design of service facilities to meet future demands provided however, that the Corporation shall pay the expense of such upgrading in excess of that which is reasonably allocable to the level and manner of service requested by the Applicant.
 - e. The Corporation's engineer will determine the fire flow design for any non-standard service request, including new subdivisions, based on density, type of structure, and other factors.
5. **Non-Standard Service Contract.** Applicants requesting or requiring Non-Standard Service shall be requested to execute a written contract, drawn up by the Corporation's Attorney (See example Section I Sample Forms), in addition to submitting the Corporation's Non-Standard Service Application. Said contract shall define the terms of service prior to construction of required service facilities. The service contract may include, but is not limited to:
- a. All costs associated with required administration, design, construction, and inspection of facilities for water service to the Applicant's service area and terms by which these costs are to be paid.
 - b. Procedures by which the Applicant shall accept or deny a contractor's bid, thereby committing to continue or discontinue the project.
 - c. Terms by which service capacity shall be reserved for the Applicant and duration of reserved service with respect to the demand which the level and manner of the service will have upon the Corporation's system facilities.
 - d. Terms by which the Applicant shall be reimbursed or compensated for fees duplicated in assessments for monthly rates and Equity Buy-In Fees.
 - e. Terms by which the Corporation shall administer the Applicant's project with respect to:
 - (1) Design of the Applicant's service facilities;
 - (2) Securing and qualifying bids;
 - (3) Execution of the Service Contract;
 - (4) Selection of a qualified bidder for construction;
 - (5) Dispensing advanced funds for construction of facilities required for the Applicant's service;
 - (6) Inspecting construction of facilities; and
 - (7) Testing facilities and closing the project.
 - f. Terms by which the Applicant shall indemnify the Corporation from all third party claims or lawsuits in connection with the project.

- g. Terms by which the Applicant shall dedicate, assign and convey to the Corporation all constructed facilities and related rights (including contracts, easements, rights-of-way, deeds, warranties, and so forth) by which the Corporation shall assume operation and maintenance responsibility for the Applicant's project. The Applicant shall also provide reproducible as-built drawings of all constructed facilities. The as-built drawings must verify that all facilities have been properly located within the easements conveyed to the Corporation.
- h. Terms by which the Board of Directors shall review and approve the Service Contract pursuant to current rules, regulations, and bylaws.
6. **Construction of Facilities by Applicant Prior to Execution of Service Contract.** The Corporation and the Applicant must execute a Non-Standard Service Contract prior to the purchase of supplies and materials or initiation of construction of facilities by the Applicant. In the event that the Applicant commences construction of any such facilities prior to execution of a Contract with the Corporation, then the Corporation may refuse to provide service to the Applicant or, in a subdivision, to any person purchasing a lot or home from the Applicant. Alternatively, the Corporation may require full costs of replacing/repairing any facilities constructed without prior execution of a contract from any person buying a lot or home from Applicant. At a minimum, the Corporation will require that all facilities be uncovered by the Applicant for inspection by the Corporation, require that any facilities not approved by the Corporation be replaced, and take any other lawful action determined appropriate by the Board of Directors of the Corporation.
7. **Dedication of Water System Extension to the Corporation.**
- Upon proper completion of construction of all on-site and off-site service facilities to meet the level and manner of service requested by the Applicant (the "Facilities"), the Facilities shall become the property of the Corporation. The Facilities shall thereafter be owned and maintained by the Corporation subject to the warranties required of Applicant under subsection 7(b) below. Any connection of individual customers to the Facilities shall be made by the Corporation.
 - Upon transfer of ownership of the Facilities, Applicant shall warrant materials and performance of the Facilities constructed by Applicant for one (1) year following the date of the transfer.
8. **Property and Right-of-Way Acquisition.** With regard to construction of facilities, the Corporation shall require private right-of-way easements or purchase of private property as per the following conditions:
- If the Corporation determines that right-of-way easements or facility sites outside the Applicant's property are required, the Applicant shall secure easements or else title to facility sites in behalf of the Corporation. All right-of-way easements and property titles shall be researched, validated, and filed by the Corporation at the expense of the Applicant. (See Sample Application Packet RUS Form 442-8 or 442-9 (Rev. 6-06))
 - All additional costs associated with facilities that must be installed in public rights-of-way on behalf of the Applicant, due to the inability of the Applicant to secure private right-of-way easements, such as including road bores and TxDOT approvals shall be paid by the Applicant. Alternatively, Applicant shall pay all costs, including legal and other professional fees and the condemnation award in the event Corporation secures such private easements or facility sites through eminent domain proceedings.
 - The Corporation shall require an exclusive dedicated right-of-way easement on the Applicant's property (as required by the size of the planned facilities and as determined by the Corporation) and title to property required for other on-site and off-site facilities.
 - Easements and facilities sites shall be prepared for the construction of the Corporation's pipelines and facility installations in accordance with the Corporation's requirements and at the expense of the Applicant.
9. **Bids for Construction.** The Corporation's Consulting Engineer shall advertise for bids for the construction of the Applicant's proposed facilities in accordance with generally accepted practices. Plans and specifications shall be made available, with or without charge (as per Engineer's determination), to prospective bidders. Although the Corporation reserves the right to reject any bid or contractor, the Corporation shall generally award the contract to the lowest qualified bidder in accordance with the following criteria:
- The Applicant shall sign the Service Contract noting willingness to proceed with the project and shall pay all costs in advance of construction associated with the project;
 - The Contractor shall provide an adequate bid bond under terms acceptable to the Corporation;
 - The Contractor shall secure adequate performance and payment bonding for the project under terms acceptable to the Corporation;

Approved DLK
Revision Date: January 1, 2023

MUSTANG VALLEY WATER SUPPLY CORP.
IS AN EQUAL OPPORTUNITY PROVIDER.

- d. The Contractor shall supply favorable references acceptable to the Corporation;
 - e. The Contractor shall qualify with the Corporation as competent to complete the work (including but not limited to current water license, OSHA competent person training, and other licenses/certificates as required to complete the project); and
 - f. The Contractor shall provide adequate certificates of insurance as required by the Corporation.
10. **Pre-Payment for Construction and Service.** After the Applicant has executed the Service Agreement, the Applicant shall pay to the Corporation all costs necessary for completion of the project prior to construction and in accordance with the terms of the Non-Standard Service Contract.
11. **Construction.**
- a. All roadwork pursuant to state, county and/or municipal standards (as applicable) shall be completed prior to facility construction to avoid future problems resulting from road right-of-way completion and excavation. Subject to approval of the requisite authority, approved road sleeves /casings may be installed prior to road construction to avoid road damage during construction of Applicant's facilities.
 - b. The Corporation shall, at the expense of the Applicant, inspect the facilities to ensure compliance with Corporation standards.
 - c. Construction plans and specifications shall be strictly adhered to, but the Corporation reserves the right to issue change-orders of any specifications, due to unforeseen circumstances during the design phase, to better facilitate construction or operation of the Applicant's facility. All change-order amounts shall be charged to the Applicant.

PART II Request for Service to Subdivided Property

This section contains additional requirements for applicants that are developers as defined in Section C Definitions.

1. **Sufficient Information.** Applicants shall provide the corporation sufficient information describing the level and manner of service requested and the timeline for initiation of this service. The following is the minimum information needed for an engineering evaluation of the requested service to the property described in the application.
 - a. Completion of requirements described in Section F part I, including completing the Non-Standard Service Application.
 - b. Applicant shall provide the Corporation with details concerning access to the property during evaluation of application
 - c. Applicant shall be notified in writing by the Corporation or designated representative the timeframe within which the requested service can be provided and the costs for which the Applicant will be responsible, in accordance with the details described on the Applicant's request for service.
2. **Service within Subdivisions.** The Corporation's obligation to provide service to any customer located within a subdivision governed by this Section is strictly limited to the level and manner of the nonstandard service specified by the Applicant. The Applicant is responsible for paying for all costs necessary for non-standard service to a subdivision as determined by the Corporation under the provisions of this Tariff and specifically the provisions of this Section; if the Applicant fails to pay these costs, the Corporation has the right to require payment of these costs by any one or more of the persons purchasing lots or homes within such subdivision before the Corporation is obligated to provide water service (Texas Water Code Section 13.2502). In addition, Corporation may elect to pursue any remedies provided by the Non-Standard Service Contract if one has been executed. Applicant is advised that purchasers of lots also may have legal recourse to the Applicant under Texas law, including but not limited to Texas Water Code Section 13.257, and the Texas Business and Commerce Code Chapter 17, Subchapter E Deceptive Trade Practices & Consumer Protection Act.
 - a. The Applicant must provide the following in addition to all other information otherwise required by this section:
 - (1) Map and legal description of the area to be served using map criteria in 30 TAC 291.105(a)(2)(A-G)).
 - (2) Time frame for:
 - (a) Initiation of service;

- (b) Service to each additional or projected phase following the initial service.
 - (3) Detailed description of the nature and scope of the project/development for:
 - (a) Initial needs;
 - (b) Phased and final needs, including a map showing each phase, and the projected land uses that support the requested level of service for each phase.
 - (4) Flow and pressure for anticipated level of fire protection requested, including line size and capacity.
 - (5) Specific infrastructure needs for anticipated level of fire protection requested, including line size and capacity.
 - (6) Any additional information requested by the Corporation necessary to determine the capacity and the costs for providing the requested service.
 - (7) Copies of all required approvals, reports and studies done by or for the Applicant to support the viability of the proposed development.
- b. Applicant must provide reasonably sufficient information, in writing, to allow the Corporation to determine whether the level and manner of service specified by the Applicant can be provided within the time frame specified by the Applicant and to generally determine what capital improvements, including expansion of capacity of the Corporation's production, treatment and/or storage facilities and/or general transmission facilities properly allocable directly to the service request are needed. If the Applicant proposes development in phases, the Applicant should specify the level and manner of service and the estimated time frame within which that service must be provided for each phase, and the Applicant must depict the currently estimated location of each phase on the maps required under 30 TAC Section 291.105(a)(2)(A-G). It is important that the Applicant's written request be complete. A complete application by the Applicant should include:
- (1) The proposed improvements to be constructed by the Applicant;
 - (2) A map or plat signed and sealed by a licensed surveyor or registered professional engineer;
 - (3) The intended land use of the development, including detailed information concerning the types of land uses proposed;
 - (4) The projected water demand of the development when fully built out and occupied, the anticipated water demands for each type of land use, and a projected schedule of build-out;
 - (5) A schedule of events leading up to the anticipated date upon which service from the CCN holder will first be needed; and
 - (6) A proposed calendar of events, including design, plat approval, construction phasing and initial occupancy.

Applicant must establish that current and projected service demands justify the level and manner of service being requested. In making his/her written request for service, the Applicant must advise the Corporation that he/she may request expedited decertification from the TCEQ.

Upon payment of the required fees, the Corporation shall review Applicant's service request. If no additional information is required from Applicant, the Corporation will prepare a written report on Applicant's service request, subject to any final approval by the Corporation's governing body (if applicable) which must be completed within the 90 days from the date of application and payment of the required fees. The Corporation's written report will state whether the requested service will be provided, whether the requested service can be provided within the time frame specified by the Applicant, and the costs for which the Applicant will be responsible (including capital improvements, easements or land acquisition costs, and professional fees).

In the event the Corporation's initial review of the Applicant's service shows that additional information is needed, the Corporation will notify Applicant of the need for such additional information. Notice of the need for additional information will be made in writing within 30 days of the date the Corporation receives the Applicant payment of the required fees. Applicant should respond to the Corporation's request for additional information within 15 days of receipt of the Corporation's written request. In any case, the Corporation will provide the written report, including any final approval by the Corporation's Board (if applicable) within 90 days from the date of the initial written application and payment of all required fees.

By mutual written agreement, the Corporation and the Applicant may extend the time for review beyond the

90 days provided for expedited petitions to the TCEQ.

3. **Final approval.** Upon final approval by the Corporation and acceptance of proposal for service by the Applicant, a non-standard service contract will be executed and the corporation shall provide service according to the conditions contained in the Non-Standard Service Contract.

Approved DLK
Revision Date: January 1, 2023

MUSTANG VALLEY WATER SUPPLY CORP.
IS AN EQUAL OPPORTUNITY PROVIDER.

SECTION G
RATES AND SERVICE FEES

Unless specifically defined in this Tariff, all fees, rates and charges as stated shall be non-refundable.

1. **Service Investigation Fee.** The Corporation shall conduct a service investigation for each service application submitted at the Corporation office. An initial determination shall be made by the Corporation, without charge, as to whether the service request is Standard or Non-Standard. An investigation shall then be conducted and the results reported under the following terms:
 - a. Both classes of service require payment of a hydraulic investigation fee starting at \$75.00 and up, based on size and number of meters requested.
 - b. All Standard Service requests shall be investigated by the Corporation's engineer and all applicable costs for providing service shall be quoted in writing to the Applicant within ten (10) working days of application when practical.
 - c. All Non-Standard Service requests shall be subject to a fee, appropriate to each project, of sufficient amount to cover all administrative, legal, and engineering fees associated with investigation of the Corporation's ability to deliver service to the Applicant to:
 - (1) Provide cost estimates of the project,
 - (2) To present detailed plans and specifications as per final plat,
 - (3) To advertise and accept bids for the project,
 - (4) To present a Non-Standard Service Contract to the Applicant, and
 - (5) To provide other services as required by the Corporation for such investigation. A Non-Standard Service Contract shall be presented to the Applicant within a suitable amount of time as determined by the complexity of the project. (See Tariff Section F.)
2. **Membership Fee.** At the time the application for service is approved, a refundable Membership Fee must be paid for service requested before service shall be provided or reserved for the Applicant by the Corporation. The membership fee cannot be more than 12 times the minimum monthly base rate.
 - a. The Membership Fee for a standard 5/8" x 3/4" meter service shall be \$550 for each service unit.
 - b. Membership fee for oversized or Master Metered Accounts shall be based on the minimum monthly base rate for the size of meter requested.

Meter Size	Base Rate	Membership Fee
3/4"	\$82.50	\$825
1"	\$137.50	\$1375
1 1/2"	\$275	\$2750
2"	\$440	\$4400

3. **Easement Fee.** When the Corporation determines that private right-of-way easements and/or facilities sites are necessary to provide service to the Applicant, the Applicant shall be required to make good faith efforts to secure easements in behalf of the Corporation and/or pay all costs incurred by the Corporation in validating, clearing, and retaining such right-of-way in addition to tap fees otherwise required pursuant to the provisions of this Tariff. The costs may include all legal fees and expenses necessary to attempt to secure such right-of-way and/or facilities sites in behalf of the Applicant. (See Tariff Section E.3. and Tariff Section F.8.b.)
4. **Installation Fee.** The Corporation shall charge an installation fee for service as follows:
 - a. Standard Service shall include all current labor, materials, engineering, legal and administrative costs necessary to provide individual metered water service and shall be charged on a per tap basis as computed immediately prior to such time as metered service is requested and installed. The fee for standard installation is currently \$1,000.
 - b. Non-Standard Service shall include any and all construction labor and materials, inspection, administration, legal, and engineering fees, as determined by the Corporation under the rules of Section F of this Tariff. The minimum current fee for nonstandard installation is \$1,500, with the final fee determined by the corporation as indicated.

Approved 
Revision Date: June 17, 2024

MUSTANG VALLEY WATER SUPPLY CORP.
IS AN EQUAL OPPORTUNITY PROVIDER.

- c. Standard and Non-Standard Service Installations shall include all costs of any pipeline relocations as per Tariff Section E.3.e.
- d. Member shall have a Customer Service Inspector provide the corporation an approved report following any new construction involving plumbing before new water service is begun, or within 30 days of completed additions or changes.

5. **System Buy-In Fee.** In addition to the Membership Fee, each Applicant for new service that requires a new service tap shall be required to achieve parity with the contributions to the construction of the Corporation’s facilities capacity that have been made previously by existing Members. This fee shall be assessed immediately prior to providing service requested and shall be assigned and restricted to that property for which the service was originally requested. This fee shall be set aside for future capacity improvements such as line upgrades, new tanks, treatment, or production. The formula applied to such fee calculated annually after receipt of the system audit is as follows:

Fee Calculation:

- Fixed Assets (+)
- Land (+)
- Long Term Debt (-)

The sum of the 3 factors divided by the total number of members = approximate System Buy-In Fee. The current System Buy-In Fee is \$4000.

6. **Monthly Charges.**

a. **Base Rate**

The monthly charge for standard metered water service is for a 5/8” by 3/4” meter. The Base Rate for larger meter sizes will be determined by the following multipliers.

Meter Size	5/8" X 3/4" Meter Equivalents	Monthly Rate
5/8" X 3/4"	1.0	\$55
3/4"	1.5	\$82.50
1"	2.5	\$137.50
1 1/2"	5.0	\$275
2"	8.0	\$440

b. **Gallage Charge** - In addition to the Base Rate, a Gallage Charge shall be added at the following rates for water usage during any one (1) billing period.

- \$.00425 per gallon for 0 to 2,000 gallons
- \$.00450 per gallon for 2,001 gallons to 4,000 gallons
- \$.00500 per gallon for 4,001 gallons to 6,000 gallons
- \$.00525 per gallon for 6,001 gallons to 8,000 gallons
- \$.00575 per gallon for 8,001 gallons to 10,000 gallons
- \$.00600 per gallon for 10,001 gallons to 20,000 gallons
- \$.00650 per gallon for 20,001 gallons to 30,000 gallons
- \$.00700 per gallon for 30,001 gallons to 40,000 gallons
- \$.00750 per gallon for 40,001 gallons to 50,000 gallons
- \$.00800 per gallon for 50,001 gallons and over

The Corporation shall, as required by Texas Water Code Section 5.701, collect from each of its Members a Regulatory Assessment Fee (Tariff Section G.23.) equal to one-half of one percent of the charge for water service. This charge shall be collected in addition to other charges for utility service. This fee is collected on all charges pertaining to Tariff Section G.6: Monthly Charges of this Tariff. (30 TAC 291.76(d))

7. **Assessments.** If at the end of the fiscal year, or in the event of emergency repairs, the Board of Directors determines the total amount derived from the collection of water charges to be insufficient for the payment of all costs incident to the operation of the Corporation’s system during the year in which such charges are collected, the Board shall make and levy an assessment against each Member of the Corporation as the Board may determine or as may be required by Rural Development, so that the sum of such assessments and the amount collected from water and

Approved 
 Revision Date: June 17, 2024

MUSTANG VALLEY WATER SUPPLY CORP.
 IS AN EQUAL OPPORTUNITY PROVIDER.

other charges is sufficient to fully pay all costs of the operation, maintenance, replacement and repayment on indebtedness for the year's operations. (See Article XVIII of USDA Model Bylaws, Section 1)

8. **Late Payment Fee.** Once per billing period, a penalty of \$20.00 shall be applied to delinquent bills. This late payment penalty shall not be applied to any balance to which the penalty was applied in a previous billing, but shall be applied to any unpaid balance during the current billing period.
NOTE: The Corporation cannot charge political subdivisions and state agencies the late payment fee. (Texas Government Code Chapter 2251.021 and Tariff Section E.16.)
9. **Owner Notification Fee.** The Corporation may, at the expense of the Member, notify said Member of a renter/lessee delinquent account status prior to disconnection of service. The Owner Notification Fee shall be \$10.00 per notification. (See Miscellaneous Transaction Forms.)
10. **Mortgagee/Guarantor Notification Fee.** The Corporation shall assess a fee of \$10.00 for each notification to a Membership lien-holder under agreement prior to Membership cancellation. (See Miscellaneous Transaction Forms.)
11. **Returned Check Fee.** In the event a check, draft, or any other similar instrument is given by a person, firm, corporation, or partnership to the Corporation for payment of services provided for in this Tariff, and the instrument is returned by the bank or other similar institution as insufficient or non-negotiable for any reason, the account for which the instrument was issued shall be assessed a return check charge of \$30.00. (See Miscellaneous Transaction Forms)
12. **Disconnect / Reconnect Fee.** The Corporation shall charge a fee of \$75 for disconnecting service for payment delinquency and an additional \$75 for reconnection of the service, except for activation of service under Tariff Section E.5.b. Re-Service.
13. **Service Trip Fee.** The Corporation may charge a trip fee of \$75.00 for any service call or trip to the Member's tap as a result of a request by the Member or resident for response to damage of the Corporation's or another Member's facilities, for investigation of meter tampering. For service trips that extend beyond one hour, such as when an extended line location is required, the Corporation shall charge \$25.00 per employee per hour for each additional hour required.
14. **Equipment Damage Fee.** If the Corporation's facilities or equipment have been damaged by tampering, by-passing, installing unauthorized taps, reconnecting service without authority, or other service diversion, a fee shall be charged equal to the actual costs for all labor, material, and equipment necessary for repair, replacement, and other Corporation actions. This fee shall be charged and paid before service is re-established. If the Corporation's equipment has not been damaged, a fee equal to the actual costs for all labor, material, equipment, and other actions necessary to correct service diversions, unauthorized taps, or reconnection of service without authority shall be charged. All components of this fee will be itemized, and a statement shall be provided to the Member, Non-member or other responsible party. If the Corporation's facilities or equipment have been damaged due to negligence or unauthorized use of the Corporation's equipment, right-of-way, or meter shut-off valve, or due to other acts for which the Corporation incurs losses or damages, the Member, Non-member or other responsible party shall be liable for all labor and material charges incurred as a result of said acts or negligence.
15. **Meter Tampering and Damage to Property Penalty.** In addition to the Equipment Damage Fee, the Corporation may charge a penalty for "Tampering" as defined in Tariff Section E.22. The penalty may only be assessed against the person who committed the Tampering. An owner cannot be assessed for the Tampering committed by their tenant. The penalty shall not exceed six (6) times the Base Rate.
16. **Customer History Report Fee.** A fee of \$10.00 shall be charged to provide a copy of the Members record of past water purchases in response to a Member's request for such a record.
17. **Meter Test Fee.** The Corporation will test a Member's meter upon written request of the Member. Under the terms of Section E of this Tariff, a charge of \$60.00 may be imposed on the affected account.
18. **Transfer Fee.** An Applicant for service who is a Transferee shall complete all required application forms, etc., and pay a Transfer Fee of \$50.00.

Approved  _____
Revision Date: June 17, 2024

MUSTANG VALLEY WATER SUPPLY CORP.
IS AN EQUAL OPPORTUNITY PROVIDER.

19. **Non-Disclosure Fee.** Any customer requesting in writing that personal information under the terms of this tariff not be disclosed to the public.
20. **Information Copy Fee.** A fee for the copying of any public information will be charged to the person requesting that information in compliance with the cost rules of the Texas Government Code Section 552.261 et. seq.
21. **Customer Service Inspection Fee.** A fee of \$50 will be assessed the Applicant before permanent continuous service is provided to new construction.
22. **Franchise Fee Assessment.** A percentage fee of the amount billed for water service will be assessed each customer whose meter is located inside the corporate limits of a city, as required by that city's ordinance requiring a franchise fee.
23. **Regulatory Assessment.** General corporation funds will be used to cover the cost of this fee; this assessment is required under Texas law and TCEQ regulations.
NOTE: The regulatory assessment is not to be collected from state agencies, wholesale customers, or buyers of non-potable (not drinkable) water. (Ref. TCEQ RG-199 revised Oct. 2002; TCEQ Section 291.76 (c)).
24. **Additional Assessments.** In the event any federal, state or local government imposes on the Corporation a "per meter" fee or an assessment based on a percent of water charges, this fee or assessment will be billed and collected as a "pass through" charge to the customer.
25. **Other Fees.** All services outside the normal scope of utility operations that the Corporation may be compelled to provide at the request of a Member shall be charged to the recipient based on the cost of providing such service.

Approved _____
 Revision Date: June 17, 2024

MUSTANG VALLEY WATER SUPPLY CORP.
 IS AN EQUAL OPPORTUNITY PROVIDER.

SECTION H
DROUGHT CONTINGENCY AND
EMERGENCY WATER DEMAND MANAGEMENT PLAN

1. ***Introduction.***

The goal of this plan is to cause a reduction in water use in response to drought or emergency conditions so that water availability can be preserved. Since emergency conditions can occur rapidly, responses must also be enacted quickly. This plan has been prepared in advance considering conditions that will initiate and terminate the water use restriction program.

A Drought/Emergency Management Committee consisting of two Board Members and the system's licensed operator will monitor usage patterns and public education efforts and will make recommendations to the Board on future conservation efforts, demand management procedures or any changes to this plan. The Committee will develop public awareness notices, bill stuffers, and other methods that will begin and continue as a constant type of reminder that water should be conserved at all times, not just during a drought or emergency. This Committee will also review and evaluate any needed amendments or major changes due to changes in the Corporation's service area population, distribution system or supply. This review and evaluation will be done on a regular basis of five years unless conditions necessitate more frequent amendments.

The plan will be implemented according to the three stages of water use restrictions as imposed by the Board. Paragraph 3 describes the conditions that will trigger these stages.

2. ***Coordination with Regional Water Planning Group.***

A copy of this Plan has been provided to the TCEQ.

3. ***Trigger Conditions.***

The Drought Emergency Management Committee is responsible for monitoring water supply and demand conditions on a monthly basis (or more frequently if conditions warrant) and shall determine when conditions warrant initiation or termination of each stage of the plan, that is, when the specified triggers are reached. The Committee will monitor monthly operating reports, water supply or storage tank levels as needed to determine when trigger conditions are reached. The triggering conditions described below take into consideration: the vulnerability of the water source under drought of record conditions, the production, treatment and distribution capacities of the system, and member usage based upon historical patterns.

- a. **Stage I - Mild Condition:** Stage I water allocation measures may be implemented when one or more of the following conditions exist:
 - (1) Water consumption has reached 80 percent of daily maximum supply for three (3) consecutive days.
 - (2) Water supply is reduced to a level that is only 20 percent greater than the average consumption for the previous month.
 - (3) There is an extended period (at least eight (8) weeks) of low rainfall and daily use has risen 20 percent above the use for the same period during the previous year.
- b. **Stage II - Moderate Conditions:** Stage II water allocation measures may be implemented when one of the following conditions exist:
 - (1) Water consumption has reached 90 percent of the amount available for three consecutive days.
 - (2) The water level in any of the water storage tanks cannot be replenished for three (3) consecutive days.
- c. **Stage III - Severe Conditions:** Stage III water allocation measures may be implemented when one of the following six conditions exist:
 - (1) Failure of a major component of the system or an event which reduces the minimum residual pressure in the system below 20 psi for a period of 24 hours or longer.
 - (2) Water consumption of 95 percent or more of the maximum available for three (3) consecutive days.
 - (3) Water consumption of 100 percent of the maximum available and the water storage levels in the system drop during one 24-hour period.
 - (4) Natural or man-made contamination of the water supply source(s).
 - (5) The declaration of a state of disaster due to drought conditions in a county or counties served by the

Approved DLK
 Revision Date: January 1, 2023

MUSTANG VALLEY WATER SUPPLY CORP.
 IS AN EQUAL OPPORTUNITY PROVIDER.

Corporation.

(6) Other unforeseen events which could cause imminent health or safety risks to the public.

4. **Stage Levels of Water Allocations.**

The stage levels of water allocations are to be placed in effect by the triggers in Paragraph 3. The System shall institute monitoring and enforce penalties for violations of the Drought Plan for each of the Stages listed below. The water allocation measures are summarized below.

a. **Stage I - Mild Conditions**

- (1) Alternate day, time of day, or duration restrictions for outside water usage allowed. (System will notify Members which restriction is in effect)
- (2) The system will reduce flushing operations.
- (3) Reduction of Members' water use will be encouraged through notices on bills or other methods.

b. **Stage II - Moderate Conditions**

- (1) All outside water use is prohibited (except for a livestock or other exemption or variance granted under this section).
- (2) Make public service announcements as conditions change via local media (TV, radio, newspapers, etc.).

c. **Stage III - Severe Conditions**

- (1) All outside watering prohibited (including livestock or other exemptions or variances granted under the previous section).
- (2) Water use will be restricted to a percentage of each Member's prior month usage. This percentage may be adjusted as needed according to demand on the system. Notice of this amount will be sent to each Member.
- (3) Corporation shall continue enforcement and educational efforts.

NOTE: Refer to the Corporation's water tariff for additional restrictions/requirements that may be imposed.

- There may be additional restrictions imposed by Governmental Entities.
- Meters will be read as often as necessary to ensure compliance with this program for the benefit of all Members.

5. **Initiation and Termination Procedures.**

Once a trigger condition occurs, the Corporation, or its designated responsible representative, shall, based on recommendation from the Chairperson of the Drought/Emergency Management Committee, decide if the appropriate stage of water use restrictions shall be initiated. The initiation may be delayed if there is a reasonable possibility the water system performance will not be compromised by the condition. If water allocation is to be instituted, written notice to the Members shall be given.

Notice of the proposed water use restrictions measure shall be communicated to each affected Member upon the initiation of each stage. Notice may be sent by email only if the Member chooses the option to receive email notices instead of mailed notices and provides a valid email address. In addition, upon adoption of Stage II or Stage III, a notice will be placed in a local newspaper or announced on a local radio or television station. The Member notice shall contain the following information:

- a. The date water restriction shall begin,
- b. The expected duration,
- c. The stage (level) of water allocations to be employed,
- d. Penalty for violations of the water allocation program, and
- e. Affected area or areas.

If the water allocation program extends 30 days, then the Chairperson of the Drought/Emergency Management Committee or manager shall present the reasons for the allocations at the next scheduled Board Meeting and shall request the concurrence of the Board to extend the allocation period.

When the trigger condition no longer exists then the responsible official may terminate the water allocations provided that such an action is based on sound judgment. Written notice of the end of allocations shall be given to Members. A water allocation period may not exceed 60 days without extension by action of the Board.

Approved DLK
Revision Date: January 1, 2023

MUSTANG VALLEY WATER SUPPLY CORP.
IS AN EQUAL OPPORTUNITY PROVIDER.

6. **Penalties for Violations.**

- a. **First Violation** – The Corporation will assess a penalty of \$25.00. The Member will be notified by a written notice of their specific violation and their need to comply with the tariff rules. The notice will show the amount of penalty to be assessed and inform the Member that failure to pay the penalty within 10 business days of receipt of the written notice will result in termination of service. Reconnection will require payment of the penalty and a charge for the service call to restore service. The notice will also inform the Member that additional violations will trigger more severe penalties and may result in termination of service regardless of whether the Member pays the penalties.
- b. **Second Violation** - The Corporation will assess a penalty of \$100.00. The notice of second violation will show the amount of penalty to be assessed and will inform the Member that failure to pay the penalty within 10 business days of receipt of the written notice will result in termination of service to be restored only upon payment of penalty and service call to restore service. The notice will also inform the Member that additional violations will trigger more severe penalties and may result in termination of service regardless of whether the Member pays the penalties.
- c. **Subsequent Violations** - The Corporation will assess an additional penalty of \$200.00 for violations continuing after the Second Violation. The notice of subsequent violation will show the amount of the penalty to be assessed and will inform the violator that failure to pay the penalty within 10 business days of receipt of the written notice will result in termination of service to be restored only upon payment of penalty and service call to restore service. The notice will also inform the Member that the Corporation may also install a flow restricting device in the Member's meter service to limit the amount of water that will pass through the meter in a 24-hour period. The costs of this procedure will be for the actual work and equipment and shall be paid by the Member. Removal of this device will be considered Meter Tampering and will result in disconnection of service without further notice. The notice of subsequent violation will also inform the Member that additional penalties will be assessed for additional violations; and in addition to penalties, that water service will be terminated for a period of three (3) days regardless of whether the Member pays the penalties for the additional violations.
- d. **Termination** – For each continuing violation, the Corporation will assess an additional penalty of \$200.00. Service will also be terminated for a period of three (3) days. The notice of termination will show the date on which water service will be terminated and the date on which service will be restored, unless the Member has failed to pay delinquent penalties, assessments or charges. Service will remain off until any delinquent penalty or other assessment is fully paid including a charge for the service call to restore service.

These provisions apply to all Members of the Corporation.

NOTE: PENALTY – The Corporation is allowed to charge a reasonable penalty to Members that fail to comply with the water use restriction procedures in accordance with 30 TAC 291.41(j) if:

- the penalty is clearly stated in the tariff;
- the penalty is reasonable and does not exceed six (6) times the minimum monthly bill stated in the Corporation's current tariff; and
- the Corporation has deposited the penalty in a separate account dedicated to enhancing water supply for the benefit of all the Corporation's Members.

7. **Exemptions or Waivers.**

The Drought/Emergency Management Committee may, in writing, grant temporary variance for existing water uses otherwise prohibited under this Plan if it is determined that failure to grant such variance would cause an emergency condition adversely affecting the health or sanitation for the public or the person requesting such variance. If compliance with this Plan cannot be technically accomplished during the duration of the water supply shortage or other condition for which the Plan is in effect, then alternative methods can be implemented which will achieve the same level of reduction in water use.

Persons requesting an exemption from the provisions of this Plan shall file a petition for variance with the Drought/Emergency Management Committee within five (5) days after the Plan or a particular drought response stage has been invoked or after a condition justifying the variance first occurs. All petitions for variances shall be reviewed by the Committee and shall include the following:

Approved DLK
Revision Date: January 1, 2023

MUSTANG VALLEY WATER SUPPLY CORP.
IS AN EQUAL OPPORTUNITY PROVIDER.

- a. Name and address of the petitioner(s).
- b. Purpose of water use.
- c. Specific provision(s) of the Plan from which the petitioner is requesting relief.
- d. Detailed statement as to how the specific provision of the Plan adversely affects the petitioner or what damage or harm will occur to the petitioner or others if petitioner complies with this Plan.
- e. Description of the relief requested.
- f. Period of time for which the variance is sought.
- g. Alternative water use restrictions or other measures the petitioner is taking or proposes to take to meet the intent of this Plan and the compliance date.
- h. Other pertinent information, as requested by the Committee.

8. **Variations.**

Variations granted by the Committee shall be subject to the following conditions, unless specifically waived or modified by the Committee or Board of Directors:

- a. Variations granted shall include a timetable for compliance.
- b. Variations granted shall expire when the water allocation is no longer in effect, unless the petitioner has failed to meet specified requirements. No variance allowed for a condition requiring water allocation will continue beyond the termination of water allocation under Section F. Any variance for a subsequent water allocation must be petitioned again. The fact that a variance has been granted in response to a petition will have no relevance to the Committee's decision on any subsequent petition.

No variance shall be retroactive or otherwise justify any violation of this Plan occurring prior to the issuance of the variance.

9. **Implementation.**

The Board has established a Drought/Emergency Management Committee by Resolution, the chairperson of which will be the responsible representative to make Drought and Emergency Water Management actions. This Committee will review the procedures in this plan annually or more frequently. Modifications may be required to accommodate system growth, changes in water use demand, available water supply and/or other circumstances.

This Plan was adopted by the Board at a properly noticed meeting held on August 16, 2015.

Approved DLK
Revision Date: January 1, 2023

MUSTANG VALLEY WATER SUPPLY CORP.
IS AN EQUAL OPPORTUNITY PROVIDER.

Service Application

Mustang Valley Water Supply Corporation

301 N. 3rd St., Suite A • P.O. Box 6
Cranfills Gap, TX 76637

CORPORATION USE ONLY	
Date Approved	_____
Account Number	_____
Service Classification	_____
Cost	_____
Work Order Number	_____
Eng. Update	_____
Service Inspection Date	_____

INSTRUCTIONS: Form must be completed by applicant.
A map of service location request must be attached. Please Print.

DATE _____ Gate Code _____ or MVWSC Double lock with Member

ACCOUNT NAME _____

APPLICANT'S NAME _____ DRIVER'S LICENSE NUMBER 1 _____

CO-APPLICANT'S NAME _____ DRIVER'S LICENSE NUMBER 2 _____

EMAIL ADDRESS 1 _____ EMAIL ADDRESS 2 _____

CURRENT BILLING ADDRESS _____ CITY _____ ST _____ ZIP _____

FUTURE BILLING ADDRESS _____ CITY _____ ST _____ ZIP _____

PHONE NUMBERS HOME (____) _____ - _____ WORK (____) _____ - _____ CELL (____) _____ - _____

911 ADDRESS AND LEGAL DESCRIPTION OF PROPERTY (INCLUDE NAME OF ROAD, SUBDIVISION WITH LOT AND BLOCK NUMBER)

LEGAL PROOF OF OWNERSHIP PROVIDED (WARRANTY DEED, DEED OF TRUST, OTHER) _____

SPECIAL SERVICE NEEDS OF APPLICANT _____

NUMBER IN FAMILY _____ ACREAGE _____ LIVESTOCK TYPE & NUMBER _____ / _____

IF TRANSFERRING MEMBERSHIP:

PREVIOUS OWNER'S NAME _____ PHONE NUMBER _____

PREVIOUS OWNER'S ADDRESS STREET _____ CITY _____ ST _____ ZIP _____

The following information is requested by the Federal Government in order to monitor compliance with Federal laws prohibiting discrimination against applicants seeking to participate in this program. You are not required to furnish this information, but are encouraged to do so. This information will not be used in evaluating your application or to discriminate against you in any way. However, if you choose not to furnish it, we are required to note the race/national origin of individual applicants on the basis of visual observation or surname.

Race: Native Hispanic or Latino Not of Hispanic or Latino

Ethnicity: American Indian/Alaska Asian Black or African American
 Native Hawaiian or Other Pacific Islander White

Gender: Male Female

Approved DLK
Revision Date: January 1, 2023

MUSTANG VALLEY WATER SUPPLY CORP.
IS AN EQUAL OPPORTUNITY PROVIDER.

Service Agreement made this _____ day of _____, _____, between **Mustang Valley Water Supply Corporation**, a corporation organized under the laws of the State of Texas (hereinafter called the Corporation) and _____ (hereinafter called the Applicant and/or Member),

WITNESSETH:

The Corporation shall sell and deliver water service to the Applicant and the Applicant shall purchase, receive, and/or reserve service from the Corporation in accordance with the bylaws and tariff of the Corporation as amended from time to time by the Board of Directors of the Corporation. Upon compliance with said policies, including payment of a Membership Fee, the Applicant qualifies for Membership as a new applicant or continued Membership as a transferee and thereby may hereinafter be called a Member.

The Member shall pay the Corporation for service hereunder as determined by the Corporation's tariff and upon the terms and conditions set forth therein, a copy of which has been provided as an information packet, for which Member acknowledges receipt hereof by execution of this agreement. A copy of this agreement shall be executed before service may be provided to the Applicant.

The Board of Directors shall have the authority to discontinue service and cancel the Membership of any Member not complying with any policy or not paying any utility fees or charges as required by the Corporation's published rates, fees, and conditions of service. At any time service is discontinued, terminated or suspended, the Corporation shall not re-establish service unless it has a current, signed copy of this agreement.

If this agreement is completed for the purpose of assigning utility service as a part of a rural domestic water system loan project contemplated with the Rural Development, an Applicant shall pay an Indication of Interest Fee in lieu of a Membership Fee for the purposes of determining:

- a. The number of taps to be considered in the design and
- b. The number of potential ratepayers considered in determining the financial feasibility of constructing
 - (1) A new water system or
 - (2) Expanding the facilities of an existing water system.

The Applicant hereby agrees to obtain, utilize, and/or reserve service as soon as it is available. Applicant, upon qualification for service under the terms of the Corporation's policies, shall further qualify as a Member and the Indication of Interest Fee shall then be converted by the Corporation to a Membership Fee. Applicant further agrees to pay, upon becoming a Member, the monthly charges for such service as prescribed in the Corporation's tariff. Any breach of this agreement shall give cause for the Corporation to liquidate, as damages, the fees previously paid as an indication of interest. In addition to any Indication of Interest Fees forfeited, the Corporation may assess a lump sum of \$300.00 as liquidated damages to defray any losses incurred by the Corporation. If delivery of service to said location is deemed infeasible by the Corporation as a part of this project, the Applicant shall be denied Membership in the Corporation and the Indication of Interest Fee, less expenses, shall be refunded. The Applicant may re-apply for service at a later date under the terms and conditions of the Corporation's policies. For the purposes of this agreement, an Indication of Interest Fee shall be of an amount equal to the Corporation's Membership Fees.

All water shall be metered by meters to be furnished and installed by the Corporation. The meter connection is for the sole use of the Member or customer and is to provide service to only one (1) dwelling or one (1) business. Extension of pipe(s) to transfer utility service from one property to another, to share, resell, or submeter water to any other persons, dwellings, businesses, or property, etc., is prohibited.

The Corporation shall have the right to locate a water service meter and the pipe necessary to connect the meter on the Member's property at a point to be chosen by the Corporation, and shall have access to its property and equipment located upon Member's premises at all reasonable and necessary times for any purpose connected with or in the furtherance of its business operations, and upon discontinuance of service the Corporation shall have the right to remove any of its equipment from the Member's property. The Member shall install, at their own expense, any necessary service lines from the Corporation's facilities and equipment to the point of use, including any customer service isolation valves, backflow prevention devices, clean-outs, and other equipment as may be specified by the Corporation. The Corporation shall also have access to the Member's property for the purpose of inspecting for possible cross-connections, potential contamination hazards, illegal lead materials, and any other violations or possible violations of state and federal statutes and regulations relating to the federal Safe Drinking Water Act or Chapter 341 of the Texas Health & Safety Code or and the corporation's tariff and service policies.

The Corporation is responsible for protecting the drinking water supply from contamination or pollution which could result from improper practices. This service agreement serves as notice to each customer of the restrictions which are in place to provide this protection.

Approved DLK
Revision Date: January 1, 2023

MUSTANG VALLEY WATER SUPPLY CORP.
IS AN EQUAL OPPORTUNITY PROVIDER.

The Corporation shall enforce these restrictions to ensure the public health and welfare. The following undesirable practices are prohibited by state regulations:

- a. No direct connection between the public drinking water supply and a potential source of contamination is permitted. Potential sources of contamination shall be isolated from the public water system by an airgap or an appropriate backflow prevention assembly in accordance with state regulations.
- b. No cross-connection between the public drinking water supply and a private water system is permitted. These potential threats to the public drinking water supply shall be eliminated at the service connection by the proper installation of an airgap or a reduced pressure-zone backflow prevention assembly and a service agreement must exist for annual inspection and testing by a certified backflow prevention device tester.
- c. No connection which allows condensing, cooling, or industrial process water to be returned to the public drinking water supply is permitted.
- d. No pipe or pipe fitting which contains more than 0.25 % lead may be used for the installation or repair of plumbing on or after July 1, 1988, at any connection which provides water for human consumption.
- e. No solder or flux which contains more than 0.2 % lead may be used for the installation or repair plumbing on or after July 1, 1988, at any connection which provides water for human consumption.

The Corporation shall maintain a copy of this agreement as long as the Member and/or premises is connected to the public water system. The Member shall allow their property to be inspected for possible cross-connections, potential contamination hazards, and illegal lead materials. These inspections shall be conducted by the Corporation or its designated agent prior to initiating service and periodically thereafter. The inspections shall be conducted during the Corporation's normal business hours.

The Corporation shall notify the Member in writing of any cross-connections or other undesirable practices which have been identified during the initial or subsequent inspection. The Member shall immediately correct any undesirable practice on their premises. The Member shall, at their expense, properly install, test, and maintain any backflow prevention device required by the Corporation. Copies of all testing and maintenance records shall be provided to the Corporation as required. Failure to comply with the terms of this service agreement shall cause the Corporation to either terminate service or properly install, test, and maintain an appropriate backflow prevention device at the service connection. Any expenses associated with the enforcement of this agreement shall be billed to the Member.

In the event the total water supply is insufficient to meet all of the Members, or in the event there is a shortage of water, the Corporation may initiate the Emergency Rationing Program as specified in the Corporation's Tariff. By execution of this agreement, the Applicant hereby shall comply with the terms of said program.

By execution hereof, the Applicant shall hold the Corporation harmless from any and all claims for damages caused by service interruptions due to waterline breaks by utility or like contractors, tampering by other Member/users of the Corporation, normal failures of the system, or other events beyond the Corporation's control.

The Applicant shall grant to the Corporation permanent recorded easement(s) dedicated to the Corporation for the purpose of providing reasonable rights of access and use to allow the Corporation to construct, maintain, replace, upgrade, parallel, inspect, test and operate any facilities necessary to serve that Applicant as well as the Corporation's purposes in providing system-wide service for existing or future members.

By execution hereof, the Applicant shall guarantee payment of all other rates, fees, and charges due on any account for which said Applicant owns a Membership Certificate. Said guarantee shall pledge any and all Membership Fees against any balance due the Corporation. Liquidation of said Membership Fees shall give rise to discontinuance of service under the terms and conditions of the Corporation's tariff.

By execution hereof, the Applicant agrees that non-compliance with the terms of this agreement by said Applicant shall constitute denial or discontinuance of service until such time as the violation is corrected to the satisfaction of the Corporation. Any misrepresentation of the facts by the Applicant on any of the four pages of this agreement shall result in discontinuance of service pursuant to the terms and conditions of the Corporation's tariff.

Applicant Member 1

Date

Applicant Member 2

Date

Office Use:

Witness

Date Approved and Accepted

Approved DLK
Revision Date: January 1, 2023

MUSTANG VALLEY WATER SUPPLY CORP.
IS AN EQUAL OPPORTUNITY PROVIDER.